

# Investigation of March 15, 2018 Pedestrian Bridge Collapse at Florida International University, Miami, FL

U.S Department of Labor  
Occupational Safety and Health Administration  
Directorate of Construction

June 2019



# **REPORT**

## **Investigation of March 15, 2018 Pedestrian Bridge Collapse at Florida International University, Miami, FL**

June 2019

**Report prepared by**  
**Mohammad Ayub, PE, SE**  
Director, Office of Engineering Services  
Directorate of Construction  
OSHA National Office  
Washington, D.C.

**TABLE OF CONTENTS**

**PAGE NO.**

1. Executive Summary:.....	9
2. Introduction: .....	13
3. Key Participants:.....	16
4. Description of Construction: .....	18
5. Peer review: .....	36
6. The cracks.....	39
7. The collapse.....	83
8. Structural analysis: .....	103
9. Structural design deficiencies:.....	106
10. Conclusions .....	113

## LIST OF FIGURES

Figure 1 Location of the bridge .....	13
Figure 2 Flow chart of the organization.....	17
Figure 3 Bridge as designed.....	18
Figure 4 Construction sequence.....	19
Figure 5 Main span truss PT bar details.....	20
Figure 6 Construction of the main span.....	21
Figure 7 Transportation of the main span.....	22
Figure 8 Bracing plan of the north end of the main span.....	25
Figure 9 Bracing of the north end of the main span .....	26
Figure 10 Cross section of the bridge main span deck .....	29
Figure 11 Main span deck end diaphragm and the post-tensioning tendons .....	30
Figure 12 Main span deck longitudinal tendon ducts .....	31
Figure 13 Diaphragm II reinforcement.....	33
Figure 14 Concrete testing report .....	35
Figure 15 Photo #1 in 2/28/2018 E-mail from MCM to FIGG.....	40
Figure 16 Photo #2 in 2/28/2018 E-mail from MCM to FIGG.....	41
Figure 17 Photo #3 in 2/28/2018 E-mail from MCM to FIGG.....	42
Figure 18 Photo #4 in 2/28/2018 E-mail from MCM to FIGG.....	43
Figure 19 Photo #5 in 2/28/2018 E-mail from MCM to FIGG.....	44
Figure 20 Photo #6 in 2/28/2018 E-mail from MCM to FIGG.....	45
Figure 21 Location of cracks in 2/28/2018 E-mail from MCM to FIGG as per BPA.....	46
Figure 22 North end of the main span truss during transportation, generally free of cracks.....	47
Figure 23 Screenshot of Kevin Hanson’s message to Sam Nunez on March 10, 2018.....	49
Figure 24 Cracks at the west side diaphragm II MCM email of 3/12/2018 – top face, by BPA..	51
Figure 25 Cracks at the west side diaphragm II MCM email of 3/12/2018, by BPA – side face.	52
Figure 26 Cracks at the east side diaphragm II MCM email of 3/12/2018, by BPA – top face...	53
Figure 27 Cracks on the east side diaphragm II MCM email of 3/12/2018, by BPA – side face.	54
Figure 28 Diagonal cracks on the west side of diaphragm II on 3/13/2018, by BPA – top face..	57
Figure 29 Close-up of cracks at the west side of diaphragm II on 3/13/2018, by BPA .....	58
Figure 30 Notice the depth and width of diagonal cracks at the west side of diaphragm II on 3/14/2018 by BPA.....	59

Figure 31 Notice the depth and width of cracks near column 12 at the west side of diaphragm II on 3/14/2018 by BPA.....	60
Figure 32 Cracks at the construction joint of the main span deck and diagonal 11 on 3/13/2018 by BPA.....	61
Figure 33 Cracks at the construction joint of the main span deck and diagonal 11 on 3/13/2018 by BPA.....	62
Figure 34 Cracks at the construction joint of the main span deck and diagonal 11 on 3/13/2018 by BPA.....	63
Figure 35 Cracks at the construction joint of the main span deck, diagonal 11 and the chamfer of diagonal 11 on 3/13/2018 by BPA.....	64
Figure 36 Cracks at the construction joint of the main span deck and diagonal 11 on 3/13/2018 by BPA.....	65
Figure 37 Cracks at the construction joint of the main span deck and diagonal 11 on 3/13/2018 by BPA.....	66
Figure 38 Cracks at the construction joint of the main span deck and diagonal 11 on 3/13/2018 by BPA.....	67
Figure 39 Close-up of longitudinal cracks in diagonal 11 on 3/14/2018 by BPA.....	68
Figure 40 Close-up of longitudinal cracks in diagonal 11 on 3/13/2018 by BPA.....	69
Figure 41 Close-up of longitudinal cracks in diagonal 11 on 3/13/2018 by BPA.....	70
Figure 42 Cracks at the west side of diaphragm II on 3/14/2018 by BPA .....	71
Figure 43 Cracks at the east side diaphragm II on 3/10/2018 – top face, by Corradino.....	72
Figure 44 Cracks and movement of the column at the east side of diaphragm II on 3/14/2018 by BPA.....	73
Figure 45 Note the gap indicative of movement between sleeve pipe and concrete, pictured on 3/13/2018 by BPA.....	80
Figure 46 Bridge immediately prior to the collapse, March 15, 2018 – camera #1 .....	85
Figure 47 Bridge immediately after the collapse, March 15, 2018 – camera #1 .....	86
Figure 48 Bridge immediately prior to the collapse, March 15, 2018 – camera #2 .....	87
Figure 49 Bridge immediately after the collapse, March 15, 2018 – camera #2.....	88
Figure 50 Bridge immediately prior to the collapse, March 15, 2018 – camera #3 .....	89
Figure 51 Bridge immediately after the collapse, March 15, 2018 – camera #3.....	90
Figure 52 Column 12, diagonal 11 and part of the canopy after bridge deck and diaphragm fell to the ground, March 17, 2018, by OSHA .....	91
Figure 53 Northernmost blister and hydraulic jack attached to the lower PT bar of diagonal 11 after bridge collapse – side view, March 17, 2018 by OSHA .....	91

Figure 54 Northernmost blister and hydraulic jack attached to the lower PT bar of diagonal 11 after bridge collapse – front view, March 17, 2018 by OSHA .....	92
Figure 55 Northernmost blister and pressure gauge, March 17, 2018 by OSHA .....	92
Figure 56 Hydraulic pump for post-tensioning after bridge collapse, March 17, 2018 by OSHA	93
Figure 57 Lower PT separated from the diagonal 11 still embedded in diaphragm after bridge collapse, March 17, 2018 by OSHA .....	93
Figure 58 Concrete blow-out failure in Diaphragm II at the time of bridge collapse at the site looking north from south, March 21, 2018, by OSHA .....	94
Figure 59 Concrete blow-out failure in Diaphragm II at the time of bridge collapse at the site looking north from south, March 21, 2018, by OSHA .....	94
Figure 60 Concrete blow-out failure in Diaphragm II at the time of bridge collapse at the site looking north from south, March 21, 2018, by OSHA .....	95
Figure 61 Remnants of diaphragm II at the time of the bridge collapse in the storage yard – looking north from south, April 9, 2018, by OSHA .....	95
Figure 62 Concrete blow-out failure in Diaphragm II at the time of bridge collapse in the storage yard looking north from south, April 9, 2018, by OSHA .....	96
Figure 63 Blow-out hole in Diaphragm II at the time of the bridge collapse in the storage yard looking north from south, April 9, 2018, by OSHA .....	96
Figure 64 Punched hole in Diaphragm II at the time of the bridge collapse – from south looking towards north, April 9, 2018, by OSHA .....	97
Figure 65 Punched hole in Diaphragm II at the time of the bridge collapse – from south looking towards north, April 9, 2018, by OSHA .....	97
Figure 66 Punched hole in Diaphragm II at the time of the bridge collapse – from south looking towards north, April 9, 2018, by OSHA .....	98
Figure 67 Punched hole in Diaphragm II at the time of the bridge collapse – from south looking towards north, April 9, 2018, by OSHA .....	98
Figure 68 Punched hole in Diaphragm II at the time of the bridge collapse – from south looking towards north, April 9, 2018, by OSHA .....	99
Figure 69 Punched hole in Diaphragm II at the time of the bridge collapse – from south looking towards north, April 9, 2018, by OSHA .....	99
Figure 70 Punched hole in Diaphragm II at the time of the bridge collapse – from south looking towards north, April 9, 2018, by OSHA .....	100
Figure 71 Side view of the saved portion of the diaphragm II in storage yard, April 9, 2018, by OSHA.....	100
Figure 72 Aerial view of the collapsed bridge, March 15~18, 2018 .....	101
Figure 73 South end of the bridge after collapse – looking west.....	101
Figure 74 South end of the bridge after collapse – looking east.....	102

Figure 75 Vehicles crushed by falling bridge ..... 102  
Figure 76 Overview of the main span truss system model ..... 105  
Figure 77 Construction joint detail at diagonal 11 and deck. .... 106  
Figure 78 Potential line of crack – plan view ..... 111  
Figure 79 Potential Punching shear failure at north end – plan view ..... 112

## LIST OF TABLES

Table 1 PT schedule – Main span deck.....	30
Table 2 Truss member details – Main span .....	33
Table 3 Main span PT pre-stressed dates – deck and canopy .....	34
Table 4 Main span PT pre-stressed dates – diagonal members .....	34



## **1. Executive Summary:**

On March 15, 2018, at approximately 1:45 p.m., a pedestrian bridge under construction in Miami, Florida, collapsed. One employee and five motorists were fatally injured, and another employee permanently disabled, when the bridge fell as the motorists waited for the traffic light underneath the bridge and as the employees were performing work activities on top of the bridge structure. The bridge at the present stage of construction consisted of a single concrete truss spanning approximately 174 feet and weighing approximately 930 tons. It was placed over the piers just five days prior to the collapse. An adjoining span of concrete truss was to be constructed next over the canal to make a continuous bridge of 289 feet. The concrete bridge was cast at a nearby off-site location using what is known as Accelerated Bridge Construction (ABC) and then transported to its final location. ABC provides minimal traffic disruption. The bridge was financed through federal grants, and constructed at the campus of Florida International University (FIU) in Miami. The FIU project was a class A Local Agency Program (LAP) project. The bridge would connect the FIU campus with the City of Sweetwater where many FIU students reside.

The incident was extensively covered by live television and print media. The Occupational Safety and Health Administration (OSHA) sent officials from the agency's Fort Lauderdale Area Office, and a forensic structural engineer from the OSHA Directorate of Construction, Office of Engineering Services (OES), in Washington, D.C., to determine the cause of the collapse and whether industry or OSHA standards were violated. During the first week of investigation, OSHA maintained a 24-hour surveillance at the incident site. OSHA worked closely with the National Transportation Safety Board (NTSB) and local officials, inspecting the remnants of the fallen bridge, and interviewing contractors to determine construction activities preceding the collapse.

OSHA conducted numerous interviews, reviewed pertinent construction documents and structural computations performed by the structural engineer of record (EOR), examined the failed pieces, conducted its own structural analysis, and viewed hundreds of photographs of the bridge taken before and after the collapse.

We thank the OSHA Fort Lauderdale Area Office, particularly Assistant Area Director Juan Torres, and Compliance Officer Anthony Campos, for their untiring effort and dedication. Alan Lu, Ph.D., PE, performed finite element analysis, and Bryan Ewing Ph.D., PE, performed hand computations, both of our office. We thank NTSB, and all the NTSB field staff for their steadfast co-operation during OSHA's investigation.

As a result of the investigation, OES concludes that:

1. FIGG Bridge Engineers (FIGG), the Engineer of Record (EOR), failed to recognize that the bridge was in danger of collapsing when it inspected it hours before the collapse. The concrete truss had developed numerous wide and deep structural cracks jeopardizing the integrity of the bridge. The EOR should have immediately instructed that the bridge be shored at appropriate locations and SW 8th Street be closed. At the time of collapse, the post-tensioning bars were being re-tensioned at the specific instructions of the EOR.
2. The bridge had structural design deficiencies that contributed to the collapse during construction stage III. The cracks on the bridge occurred due to deficient structural design.
3. The morning of the incident, EOR held a meeting with project participants after evaluating the cracks over the course of the previous two days. At that meeting, the EOR acknowledged that his computations could not replicate the cracks and therefore, he did not know why the cracks were occurring. The Construction Engineer and Inspector (CEI) of the project advised the EOR at this meeting that the cracks were lengthening daily. Despite these admissions and the knowledge that the cracks were growing in size, EOR stated more than once that the cracks did not present any safety concerns.
4. The magnitude of the cracks warranted that SW 8th Street be immediately closed, and the concrete truss be shored and supported at multiple intermediate locations to reduce the loads in the north diagonal and the node until final evaluations were done and remedial measures implemented.
5. Networking Engineering Services, Inc. dba Bolton Perez and Associates, Inc. (BPA) was retained by FIU to be the CEI of the project. BPA failed to classify the cracks, which

were structural in nature, in accordance with the Florida Department of Transportation (FDOT) requirements. BPA, as a CEI, was expected to exercise its own independent professional judgement in accordance with their contract with FIU and FDOT requirements. With intimate knowledge of extensive cracking on the bridge, BPA failed to recognize that the bridge was in danger of collapsing, and did not recommend to FIU, MCM or others to close the street and shore the bridge, regardless of the opinion held by the EOR.

6. Munilla Construction Management, Inc. (MCM), the design-build contractor, was aware that the cracks were “getting larger” as reported by MCM superintendent and quality control personnel on March 12 and 14, 2018. On March 13, 2018, EOR stated in an email to MCM, among the list of facts, that “since Saturday (March 10, 2018), MCM has been monitoring the cracks and they have not grown in size.” MCM should have immediately informed EOR on March 14, 2018, that this assumption was not valid. Despite this oversight on the part of MCM, EOR was provided with photographs and measurements of the cracks in the days leading up to the collapse and was specifically informed by BPA during the morning meeting on March 15, 2018, that the cracks were lengthening.
7. MCM, the design-build contractor, deferred to the decision of EOR and failed to exercise its own independent professional judgement, as a constructor of the bridge, to close the traffic on SW 8th Street until the cause of the cracks were conclusively determined by EOR and peer reviewed. MCM had extensive construction experience in concrete structures and had intimate knowledge of the magnitude of cracks, which were growing in size daily. MCM’s deference to EOR in light of the conclusion No. 6 above, and failure to exercise their own independent judgment with regard to implementing necessary safety measures were unreasonable.
8. The evaluations of the cracks by EOR, and his recommendation to re-tension the post-tensioning bars of diagonal 11, were not included in the original design and therefore should have been subject to peer review.
9. The consultant retained by EOR to conduct independent peer review of the EOR’s design, as per FDOT requirements, did not check the structural integrity of the bridge under different construction stages, a violation of the FDOT requirements. The

independent check was performed only under the final design stage when all segments of the bridge were constructed and completed.

10. EOR failed to provide construction documents to Louis Berger at 30%, 60% and 90% of completion of construction documents, in accordance with the FDOT requirements.
11. EOR should have known that the consultant who conducted the peer review did not check the structural design of the truss design at stage III, as required by FDOT, meriting extra safety precautions by EOR.
12. EOR should have known that the truss was a non-redundant structure and if one diagonal member failed, the entire bridge could collapse. Given the nature and extent of the cracking and the non-redundancy of the bridge design, necessary safety precautions should have included closing the roadway below the bridge and immediately providing shoring to the bridge at suitable locations until a complete evaluation was done.

## 2. Introduction:

The Florida International University in Miami is one of the largest campuses in the United States. A project called UniversityCity Prosperity Project was created by FIU to improve the infrastructure of the campus. The project, among other things, included the construction of a pedestrian bridge over the SW 8th Street near SW 109th Avenue to facilitate movement of students from the adjoining City of Sweetwater to the FIU campus, as shown in Figure 1.

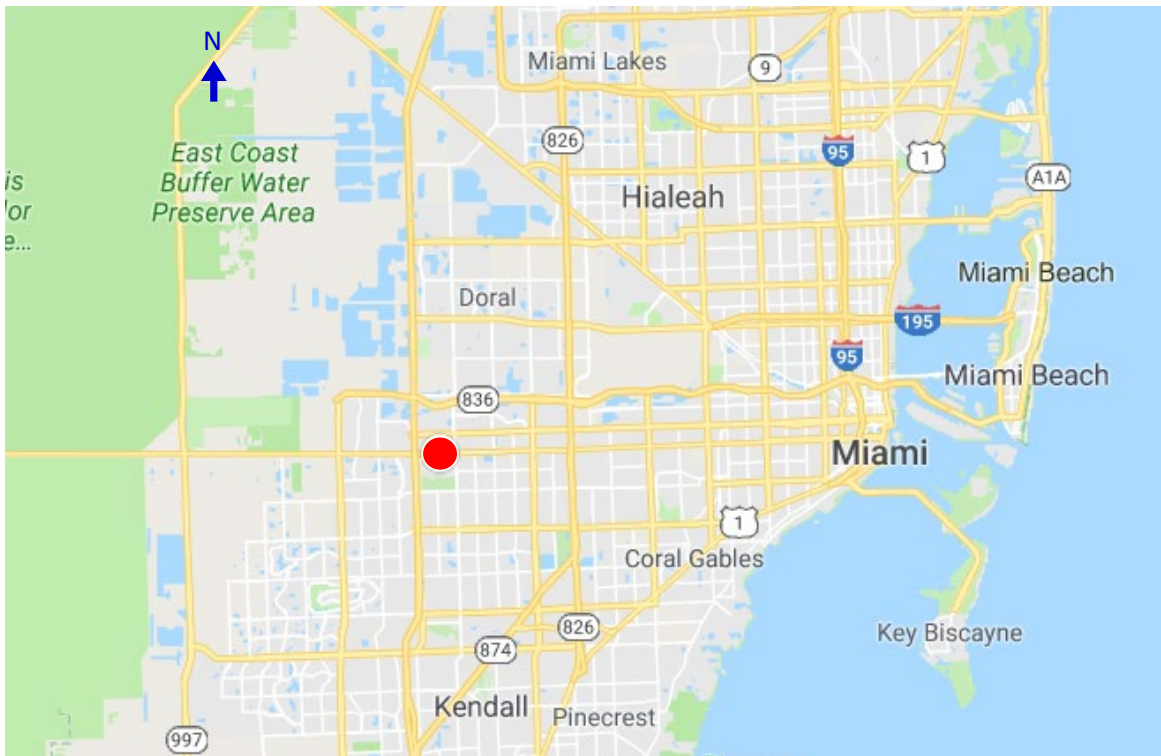

Figure 1 Location of the bridge  
(Courtesy of Google Map)

In this regard, FIU signed a series of agreements. Florida Department of Transportation (FDOT) placed the FIU UniversityCity Prosperity project under the Local Agency Program (LAP). FIU and FDOT signed the LAP agreement in June 2013. Another agreement was signed between FIU and the U.S. Department of Transportation (USDOT) and Federal Highway Administration (FHWA) under the Transportation Investment Generating Economic Recovery (TIGER) program. The federal TIGER grants represented a majority of the funds provided for the \$19

million project. The LAP agreement was amended at the request of FIU to reflect the substantial project completion date to January 2019 and completion of the project by February 2019.

FIU retained TY Lin International (TY Lin), a construction engineering company, to prepare design criteria and conceptual drawings for the pedestrian bridge project. The criteria was completed in April 2015. FIU advertised the project as a design-build project. The design criteria emphasized in great length to the prospective bidders the desired aesthetic aspect of the pedestrian bridge. The list of criteria included:

*“The structure is also an opportunity to be a landmark for the campus and serve as a gateway into western Miami-Dade County from Florida turnpike.*

*The structure should function as more than just a path for circulation. It should be a place to be experienced and the FIU Campus and its students must be proud of it. It should be a destination in its own right where community members might linger, gather, and create an urban social space-linear park.”*

The design criteria also stated that *“The bridge superstructure **should be primarily structural steel with concrete walking surface.** The design should avoid use of **non-redundant, fracture critical members.**”* (Emphasis ours). Steel structure was not a requirement in the design criteria but certainly a preference due to inherent steel’s ductility properties. Further discussion of the redundancy of the structure will follow in subsequent sections of this report.

A selection committee consisting of FIU officials, City of Sweetwater, and FDOT was established. TY Lin was not included in the selection committee. FIU received two proposals, one from Munilla Construction Management, Inc. (MCM), and the other from Facchina Construction Co. Inc., both from Florida. MCM teamed with FIGG Bridge Engineers (FIGG) of Tallahassee as a sub-contractor. FIGG was the Engineer of Record (EOR). The selection committee was impressed by the rendering of the MCM-FIGG proposal that depicted a bridge with a single line of truss members, also of concrete, and a wide bottom concrete deck and a concrete canopy. The bridge was similar to a cable-stayed bridge with plenty of walking surface and socializing area on the bridge deck. With night lighting and illumination, it would have become a milestone in the area. The proposal also employed the use of Accelerated Bridge

Construction (ABC) technique, which is researched and promoted at the FIU University Transportation Center. The selection committee selected the MCM-FIGG proposal primarily for its aesthetic considerations. The selection was sent to FDOT and FHWA for approval, which was promptly granted in November 2015.

FIU awarded the contract to MCM in December 2015. FIU issued the notice to proceed to MCM in January 2016. As stated earlier, MCM retained FIGG Bridge Engineers, Inc., of Tallahassee, FL, to perform structural design of the bridge, and manage other professionals to be retained by FIGG to design civil, mechanical, electrical, plumbing, etc. Notice to proceed was given to FIGG by MCM in January 2016 when the structural design work began. MCM and FIGG signed the contract in April 2016. FIGG had no direct contract with FIU. During the design phase, the entire bridge had to be re-positioned 11 feet towards the north to accommodate certain FDOT requirements. Because the entire bridge was moved, it did not impact the design efforts or the construction schedule.

FIU also retained BPA of Miami, FL, to perform Construction Engineering and Inspection (CEI) work.

The construction was to proceed in eight stages. See Figure 4 for the different stages of construction reproduced from the construction document prepared by FIGG. Essentially, the first stage was to cast the sub-structure. The second was to cast main span truss with all the post-tensioning of the deck, canopy and diagonals completed in the casting yard. The third was to transport the main truss over the Self-Propelled Modular Transporter (SPMT), and place the main span over the south pier and north pylon. The rest of the stages of construction consisted of casting the intermediate section of pylon, back span truss, and the rest of the pylon; and erecting support pipes, etc. The incident occurred at the third stage. The second stage provided the advantage of ABC as the disruption to the traffic on SW 8th Street was reduced to a bare minimum.

### 3. Key Participants:

The following were the key participants in the project:

- |  |                                   |
|--|-----------------------------------|
| 1. Florida International University<br>Facilities Management | Owner                             |
| 2. Florida Department of Transportation                      | LAP program                       |
| 3. Munilla Construction Management, Inc.                     | General contractor (Design-Build) |
| 4. FIGG Bridge Engineers, Inc.                               | Structural Engineer of Record     |
| 5. The Louis Berger Group, Inc.                              | Independent peer review           |
| 6. Bolton Perez and Associates, Inc.                         | CEI                               |
| 7. The Structural Group of South Florida                     | Concrete subcontractor            |
| 8. Structural Technologies /VSL, LLC                         | Post-tensioning                   |
| 9. RC Group, LLC   | Formwork and scaffold             |
| 10. Barnhart Crane & Rigging Company                         | Precast bridge transporter (SPMT) |
| 11. Georges Crane Service, Inc.,                             | Crane                             |
| 12. Cemex  | Concrete supplier                 |
| 13. The Corradino Group                                      | Post-tensioning inspection        |

The following is the flow chart of the organization as provided by FIU.



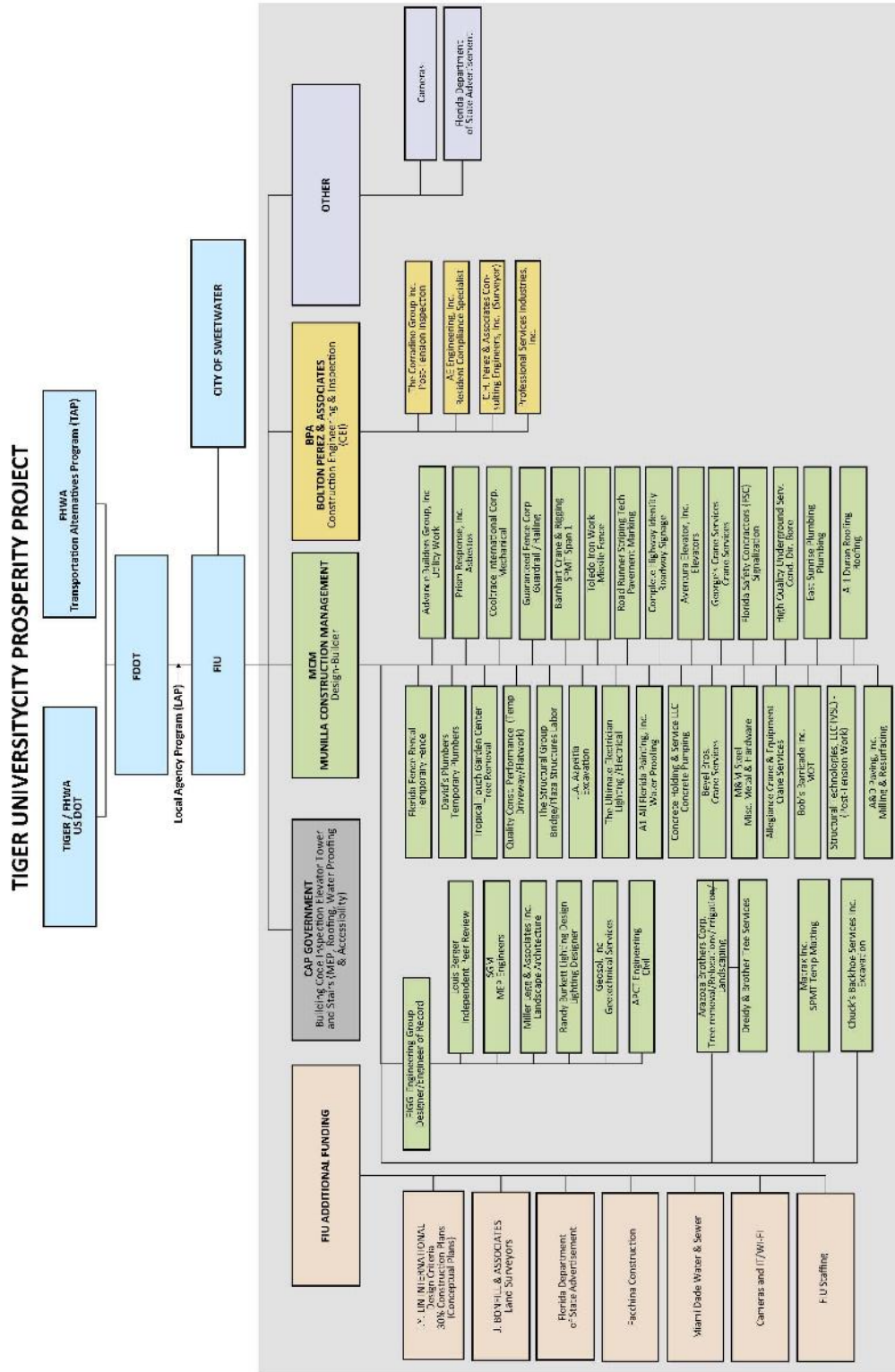

The Project Chart taken from FIU Project

Figure 2 Flow chart of the organization

#### 4. Description of Construction:

FIGG designed the bridge as a continuous single truss concrete bridge with a 31'-8" wide bottom deck and a 16' wide canopy, see Figure 10. The main span spanned from the south pier to the north pylon, and the back span from the north pylon to the north pier. The back span was located over a non-navigable canal. Eventually, both spans would become one continuous bridge. The height between the deck and the canopy was approximately 15 feet. The overall height was 18 feet. The pylon was to be approximately 109 feet with inclined steel pipes connected to the top nodal points of the truss canopies of the main and back spans. The connection points were located in a concrete pad called blisters. The tall pylon and the inclined steel pipes on the north and south sides were to provide a look of a cable stayed bridge, as shown in Figure 3.

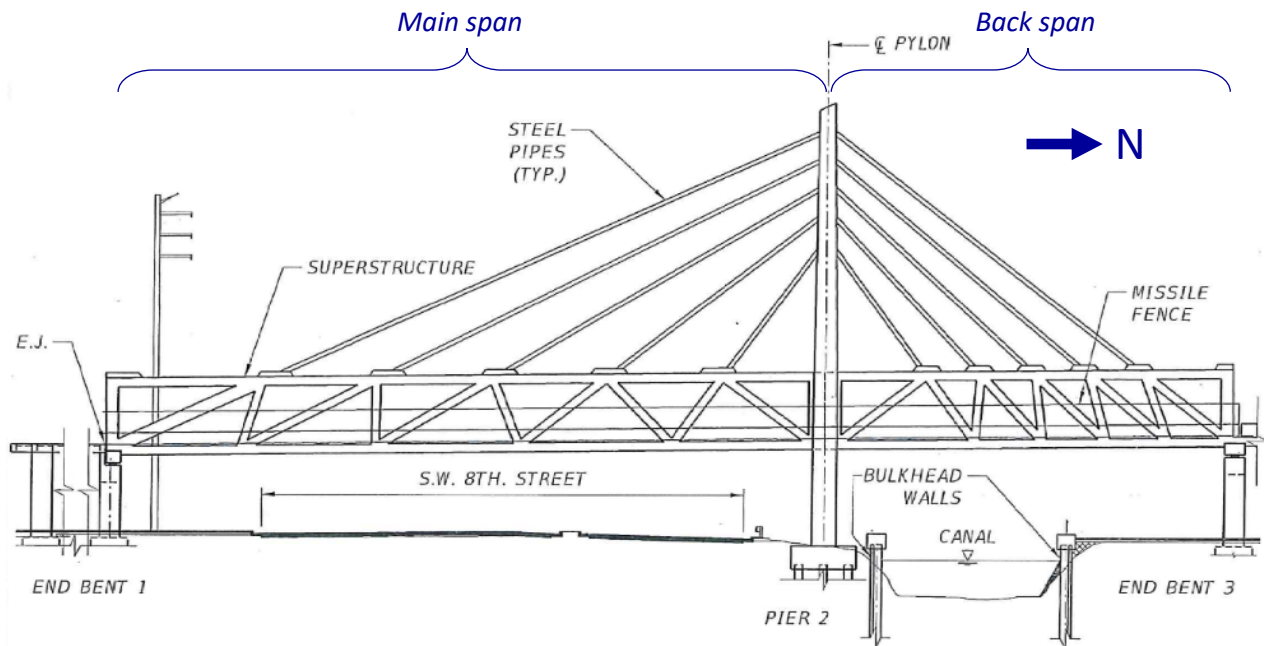

Figure 3 Bridge as designed

The construction was to be performed in stages. Figure 4 is reproduced from the construction documents outlining the various stages. In essence, the 174 ft. overall span between the south pier and the north pylon, called the main span, was to be cast at an off-site location (see Stage 2 in Figure 4 and Figure 5). The back span, 96 ft. long, was to be cast in place (see Stage 4 in Figure 4). The deck had 12 longitudinal tendons, and 65 transverse tendons. The canopy had

eight tendons but no transverse tendons. Most of the diagonals had PT bars. The main span was to be transported over the self-propelled modular transporter (SPMT) to its final location, see Stage 3 in Figure 4 and Figure 7. The main span truss when placed over the pier and pylon, was designed to be self-supporting for dead and live loads without being continuous over the back span, and without the assistance of the pylon and the inclined pipe connections.

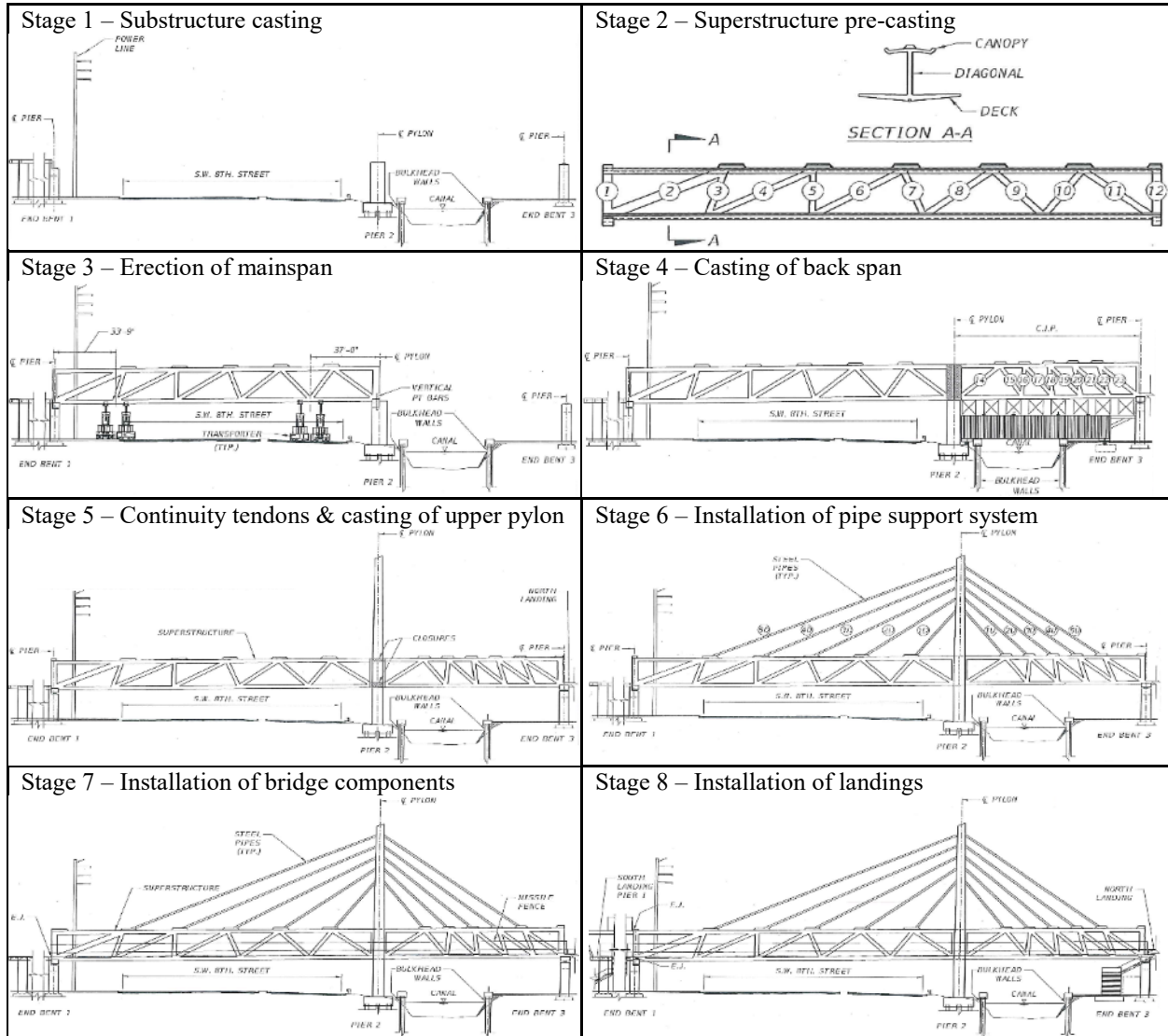

Figure 4 Construction sequence

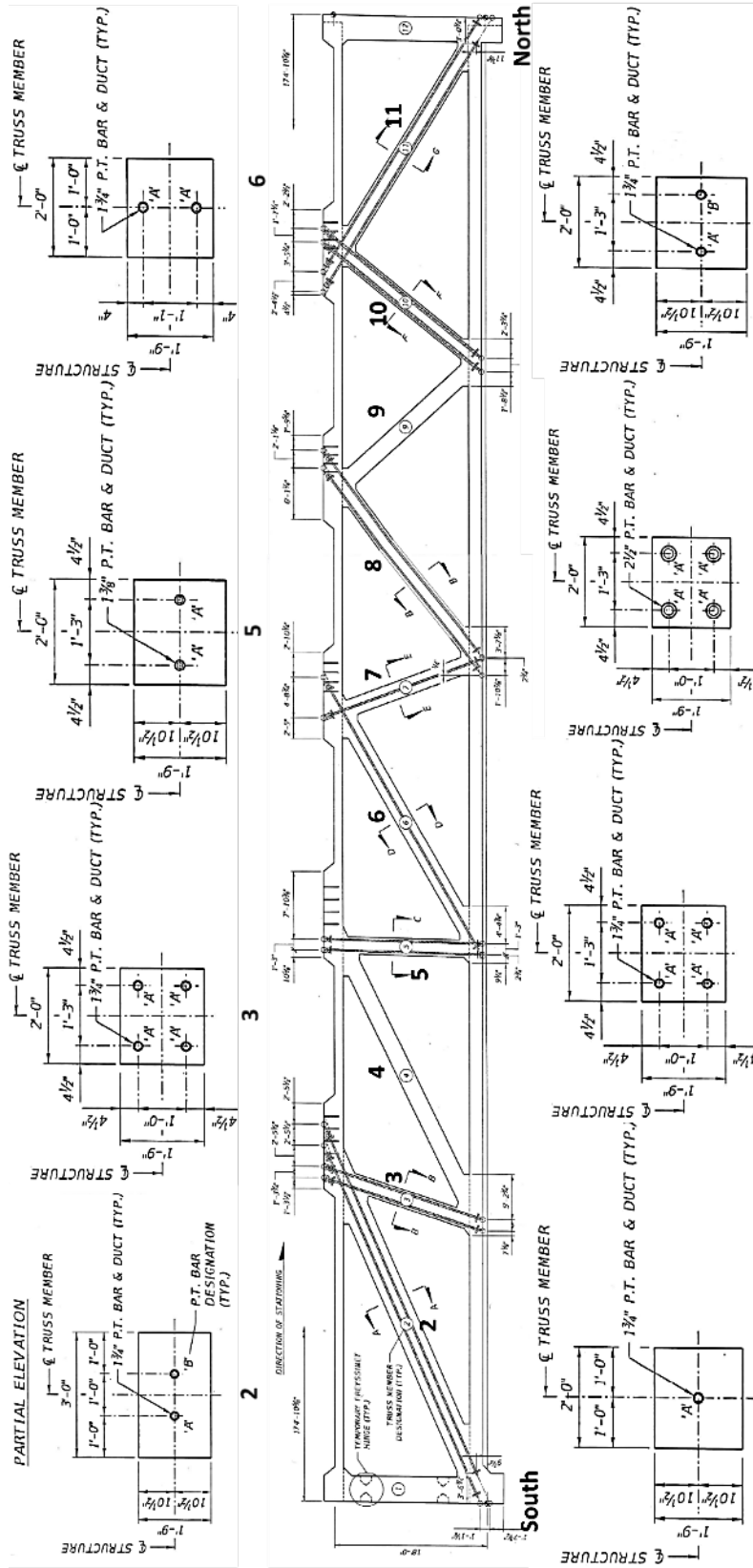

Figure 5 Main span truss PT bar details



Figure 6 Construction of the main span  
(photo by BPA, date unknown)



Figure 7 Transportation of the main span  
(photo by BPA, taken on March 10, 2018)

MCM selected a place south of SW 8th Street, on the side of the FIU campus, as a casting yard of the main span, see Figure 6. Formwork was erected for the entire truss and concrete was placed in four pours with construction joints between the pours. The first pour consisted of the deck and the diaphragms, the second was the diagonals and struts, and the third was the canopy. The fourth pour was the blisters over the canopy for connection to the future sloping steel pipes. The dates of the pour and dates of post-tensioning at the casting yard are noted below:

On or about October 18, 2017, Deck and diaphragms I and II were cast continuously in one pour.

A few days earlier, the casting of the deck had to be abandoned because after concrete in a few trucks were delivered, and after a portion of the deck on the south side was poured, the concrete supplier was unable to furnish a continuous supply of concrete. The concrete already placed on the deck forms had to be jack hammered and removed.

The Diagonals and struts were cast in pour #2 on November 6, 2017

December 14, 2017: Pour No. 3 Canopy (poured continuously)

January 16-31, 2018: Post-tensioned 12 longitudinal strands in the deck and four in the canopy.

February 8-9, 2018: Post-tensioned 65 transverse tendons in the deck

February 16-17, 2018: Post-tensioned diagonals with PT bars

Note: Except for diagonal 2 and 11, all tendons and PT bars were grouted in the deck, canopy and the diagonals at the casting yard.

After all the PT tendons and PT bars were post-tensioned, preparations were underway to move the main span to the final location.

February 23, 2018 Formwork and shoring under the bridge began to be removed.

February 24-28, 2018 Removal of formwork completed, except for the mega shores under each diaphragm. It is important to note that the lateral bracings to the diaphragm I and II were left intact, and were not removed. Also the lateral

bracings to diaphragm II were fastened to the diaphragm II itself, and not to the shores, providing significant lateral support, see Figure 8 and Figure 9. The bridge was then supported at each end on mega shores.

When the shores under the bridge were removed and the truss was self-supported over the mega shores, a loud popping sound was heard by at least three employees - one from The Structural Group (TSG), and two from MCM. The employee from the TSG and one of the employees from the MCM walked over the bridge and noticed cracks at the bases of diagonal 2 and 11.

Barnhart Crane & Rigging began bringing heavy equipment to the site in preparation for the move.



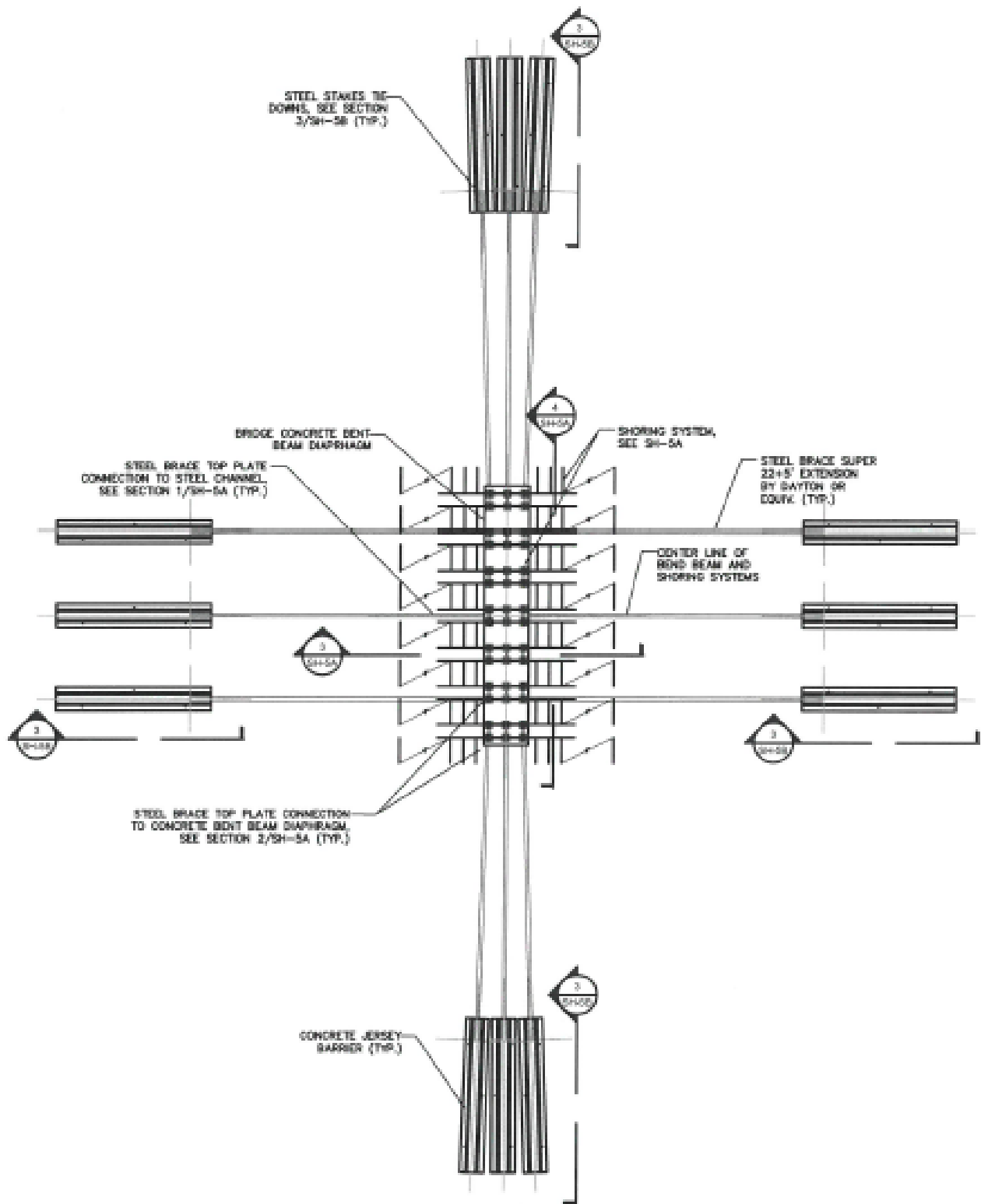

Figure 8 Bracing plan of the north end of the main span  
Reproduced from the formwork drawings, prepared by RC Group, LLC



Figure 9 Bracing of the north end of the main span  
Note: the truss formwork and shores had been removed.  
(photo by BPA, date unknown)

- March 2, 2018            Blisters of the canopy poured. Access openings for PT bars in diagonal 2 and 11, left open.
- March 9, 2018            Barnhart Crane & Rigging completed bringing all their necessary heavy equipment in preparation for the move.
- Barnhart supported the main span structure on the SPMT at locations approved by FIGG. Immediately before the move on the morning of March 10, 2018, the diagonal pipe braces to the diaphragm II were disconnected.
- March 10, 2018            At dawn, Barnhart slowly began to turn and move the main truss to the final location. First, the truss had to be rotated 90 degrees. The turn was made in a clockwise direction to correctly align the ends of the structure to the north pylon and south pier. A glitch soon occurred as the WIFI became erratic, but in an hour or so, the WIFI problem was resolved. Multiple eye witnesses reported to OSHA during interviews that the rest of the movement went smoothly.
- Several employees from different entities were present to offer assistance during the move, if and when required. Six FIGG employees – Denny Pate, Dwight Dempsey, Franklin Hines, Eddy Leon, Erika Hango and Linda Figg – all professional engineers, attended the movement.
- A review of a video, publicly available on YouTube, entitled “FIU Florida bridge collapse No Cracks” indicates that the north diaphragm was generally free of cracks at the time the main span truss was placed on the north pylon.
- It is estimated that the truss was placed over the supports around 11:30 am. Soon thereafter, MCM, BPA and FIGG employees walked over the bridge to look for anything unusual. Franklin Hines of FIGG walked over the bridge and reported no significant issues. However, on March 12,

2018, MCM sent an email to FIGG expressing its concern about the cracks MCM and BPA noticed in the afternoon of March 10, 2018.

Then, Barnhart began disengaging SPMT from the truss structure and was taken back to near the casting yard. Therefore, the truss was self-supporting with no support other than the pier and pylon.

As per B-109, the following actions were to be taken:

Stage III: Erection of main span

1. *Install bearing pads at pier 1 and shim plate at the pylon base.*
2. *Move main span from the staging area to the final location.*
3. *Grout space between the precast section diaphragm and pylon base.*
4. *Stress pylon vertical PT bars.*

After steps 1 and 2, the PT bars in diagonal 2 and 11 were also to be de-tensioned.

Steps 1 and 2 were already taken, but steps 3 and 4 were yet to be undertaken, as all attention was diverted to the cracks that developed (discussed later). Previously on March 6, 2018, FIGG had instructed that step 4 could be only taken after step 3. FIGG had also instructed that the grout should match the color of the concrete used in the super-structure. FIGG had further instructed MCM on March 6, 2018, that “*therefore, PT bars (in diagonal 2 and 11) can be destressed after span 1 is supported on the permanent supports (pylon and end bent 1).*” MCM confirmed to FIGG that “*OK, we presume it could occur any time after the setting.*” Therefore, de-stressing could occur even before step 3 and 4 were taken.

For further activities of March 10, 2018, see Chapter 6.0, the Cracks.

The deck:

A cross section of the bridge main span is reproduced below showing the geometry of the deck and the canopy. The depth of the deck varied from 9 ½” at the edge to 2’-0” at the center with a slope down to the center for drainage purposes. The center has a cutout with a radius of 6” to

install an 8" dia. drain pipe, as shown in Figure 10. PT and mild reinforcing have been provided in longitudinal and transverse direction.

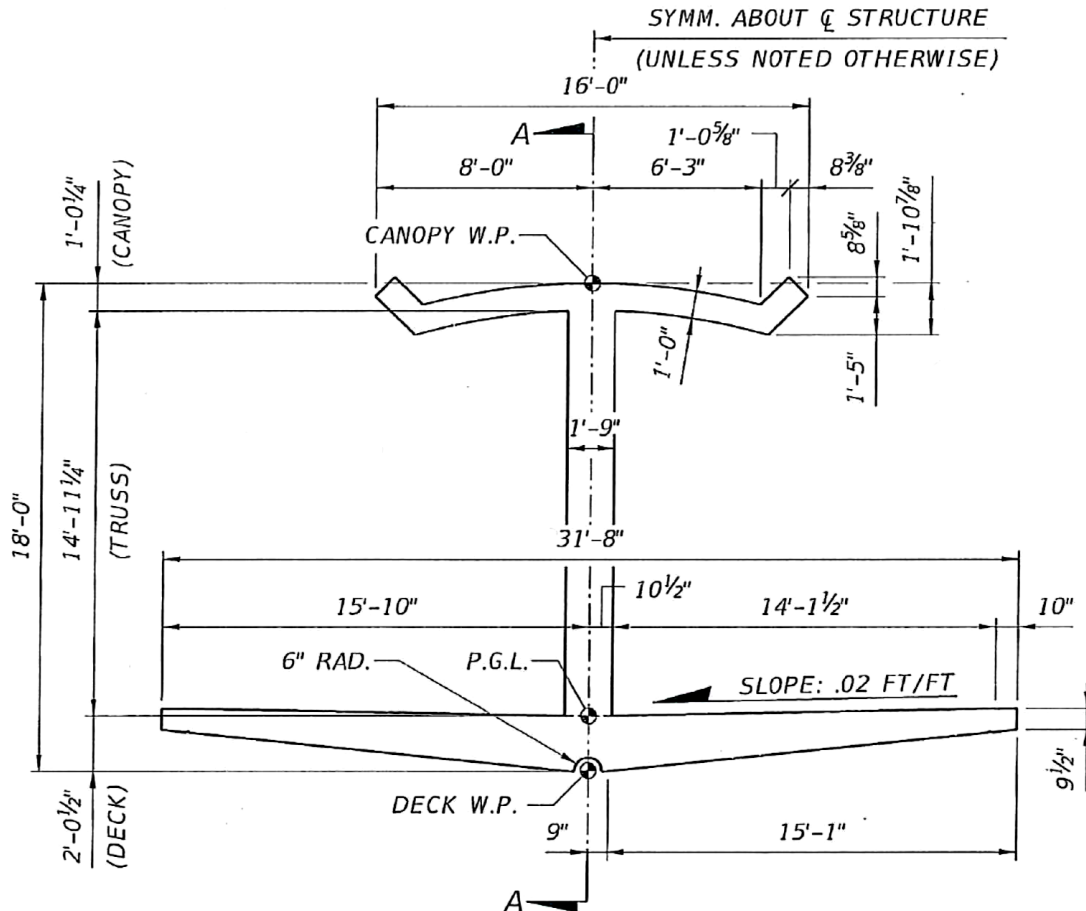

Figure 10 Cross section of the bridge main span deck

Main Span Deck longitudinal PT tendons

MCM entered into a contract with Structural Technologies, LLC (VSL) to furnish post-tensioning tendons and bars, ducts, and perform post-tensioning in various members of the structure. VSL prepared post-tensioning shop drawings and submitted them for approval through the chain. Six post-tensioning tendons, marked D1 thru D6, were provided on either side of the center line of the truss, as shown in Figure 11.

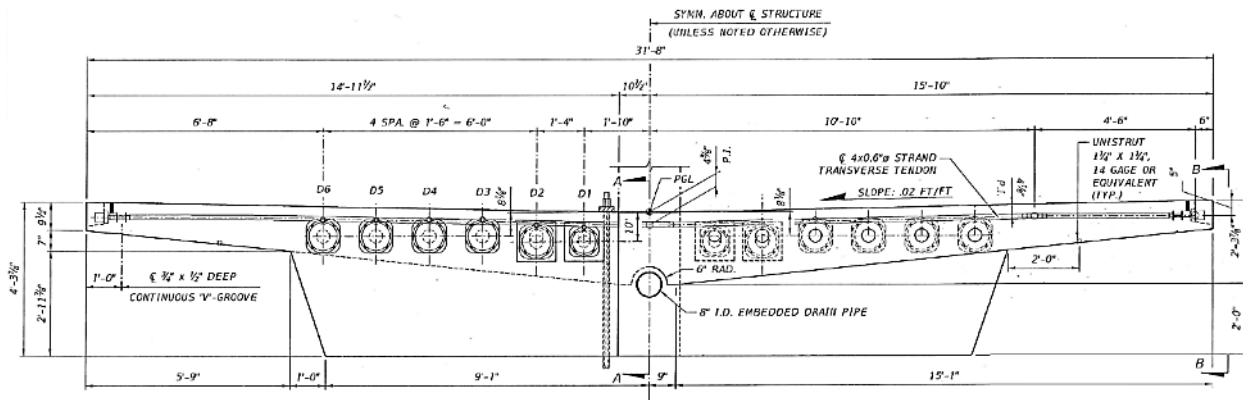

Figure 11 Main span deck end diaphragm and the post-tensioning tendons

Table 1 PT schedule – Main span deck

No.	Tendons	Force @ live end kips	Force @ dead end kips	length grouted ft.
D1	12 x 0.6	471	489	173
D2	19 x 0.6	745	775	173
D3	10 x 0.6	745	775	173
D4	19 x 0.6	745	775	173
D5	19 x 0.6	745	775	173
D6	19 x 0.6	745	775	173

The longitudinal tendons were stressed at the south end. The tendons were placed in the high density polypropylene corrugated ducts; 4" ID for the 19 strands and 3" ID for 12 strands. 300 tons maximum capacity jacks were used for 12 strands, and 500 tons maximum capacity jacks were used for 19 strands. The transverse tendons consisting of 4 strands were placed in a rectangular duct 1" x 3". Unlike longitudinal strands, the transverse strands were tensioned individually, one by one, by a single strand jack. The diagonal PT bars were encased in 3" or 3 1/2" ducts. The PT bars were tensioned by 150 – 250 tons jack depending on the size of the PT bars.



Figure 12 Main span deck longitudinal tendon ducts  
(Photo by BPA, date unknown)

Major mild reinforcements provided in the deck were bundles of three #4 rebar spaced at 12" o.c. for the entire longitudinal length of the deck at top and bottom. These bundle of #4 rebar are not provided with any hook at the ends as they are straight bars with proper lap at discontinuous locations. Four bundles have also been provided at the center of the deck. There are other reinforcements as well but the major ones have been described above. Interviews with TSG, BPA and MCM indicated that though there were congestions of rebar at certain locations, concrete was placed properly.

Main Span Deck PT tendons in transverse direction:

Sixty-five post-tensioning tendons were provided in the transverse direction consisting of 4 – 0.6 tendons spaced roughly at 2'-8" o.c.

In addition, mild reinforcements provided in the transverse directions were #5 rebar at 1'-0" o.c. at the top and two # 6 rebar at 1'-0" o.c. at bottom. Also 5' long # 5 rebar were placed in between the tendons.

Canopy longitudinal direction main span:

Two longitudinal tendons marked C1 and C4 were provided with 12- 0.6 tendons. Provisions were also made for two other tendons marked C2 and C3 to be provided later to be combined with the back span when completed. C2 and C3 also consisted of 12- 0.6 tendons. Mild reinforcements consisting of bundles of three #4 rebar were provided at 12" o.c. top and bottom.

Canopy transverse direction main span:

No transverse post-tensioning was provided in the transverse direction. However, 189 # 5 rebar were provided at top and bottom, approximately 12" o.c.

Diaphragm II reinforcements:

On the north side over the pylon, the bridge was supported over a 2 ft. wide and 4 ft. deep beam identified as diaphragm II. At the nodal point, it was 2'-10" wide for a width of 1'-9" due to column 12 intersecting the diaphragm II. The depth of the diaphragm varied due to the slope of the deck. It was 4 ft. deep over the support of the pylon. The diaphragm sat over the bearings consisting of four hard plastic pads. The primary reinforcements were six rows of #8 rebar each face of the diaphragm, and two #4 at the top face. In addition there are eight #11 rebar across the full length of the diaphragm. Multiple shear stirrups consisting of #9 and #8 bars spaced at 1'-6" were provided. See Figure 13 for details.



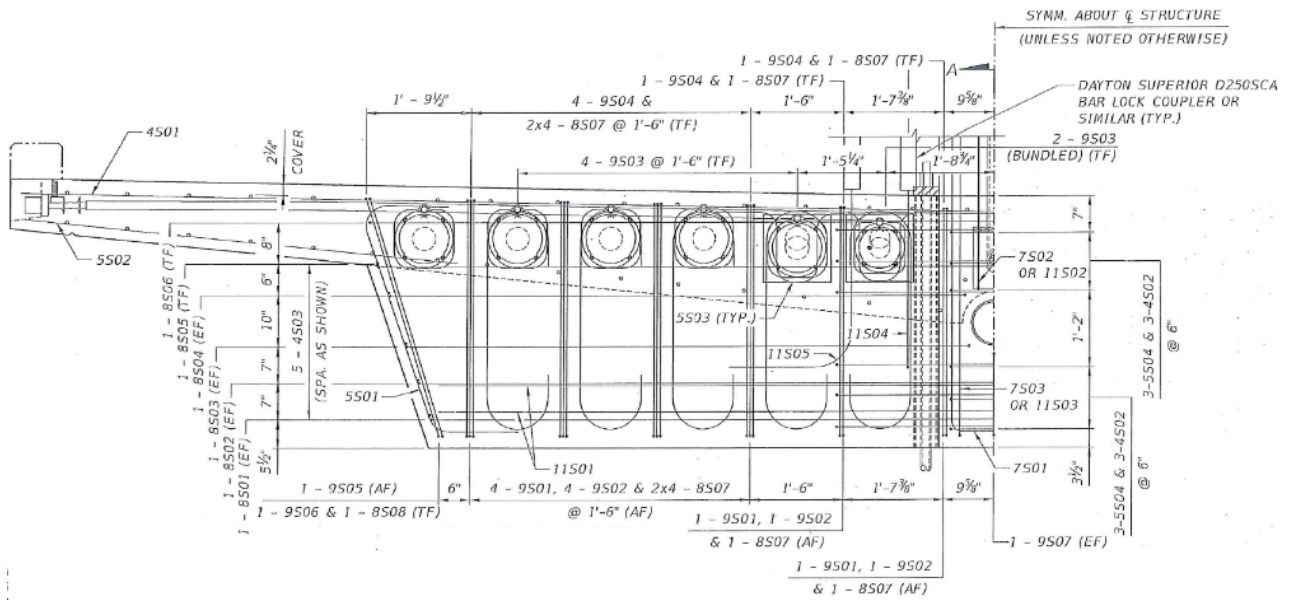

Figure 13 Diaphragm II reinforcement

Diaphragm I:

Similar to Diaphragm II except it was 3-6” wide by 4’ deep.

Members of the truss had the following dimensions and reinforcements:

Table 2 Truss member details – Main span

No.	Size	Rebar	Post-tensioning	Grouted
1	21”x36”	12 #11	None	No
2	21”x36”	12 #8	2 -1 3/4” PT bars	No
3	21x24	8 #7	4 -1 3/4”	Yes
4	21x24	10 #7	None	No
5	21x24	8 #7	2 -1 3/4”	Yes
6	21x24	8 #7	2 -1 3/4”	Yes
7	21x24	8 #7	1 -1 3/4”	Yes
8	21x24	8 #7	4 -1 3/4”	Yes
9	21x24	10 #7	None	No
10	21x24	8 #7	4 -1 3/4”	Yes
11	21x24	8 #7	2 -1 3/4”	No
12	21x34”	3 #11 and 9 # 7	None	No

Table 3 Main span PT pre-stressed dates – deck and canopy

<b>Deck &amp; Canopy Longitudinal</b>		
<b>Location</b>	<b>Date</b>	<b>Size</b>
D1R	1/23/18	12 Strands, 0.6"Ø
D1L	1/16/18	19
C2L	1/23/18	19
C2R	1/23/18	19
D2L	1/31/18	19
D2R	1/31/18	19
D3L	1/31/18	19
D3R	1/31/18	19
D4L	1/31/18	19
D4R	1/31/18	19
D5L	1/31/18	19
D5R	1/31/18	19
D6L	1/31/18	19
D6R	1/31/18	19
C3L	2/17/18	12
C3R	2/17/18	12

Table 4 Main span PT pre-stressed dates – diagonal members

<b>Diagonal PT Bars</b>			
<b>Location</b>	<b>Date</b>	<b>Size</b>	<b>Force</b>
2A	1/30/18	1 ¾	280
2B	1/13/18	1 ¾	280
11A	1/30/18	1 ¾	280
11B	1/30/18	1 ¾	280
3A-1	2/16/18	1 ¾	280
3A-2	2/16/18	1 ¾	280
3A-3	2/16/18	1 ¾	280
3A-4	2/16/18	1 ¾	280
10A-1	2/16/18	2 ½	389
10A-2	2/16/18	2 ½	389
10A-3	2/17/18	2 ½	389
10A-4	2/17/18	2 ½	389
5A-1	2/17/18	1 ⅜	166
5A-2	2/17/18	1 ⅜	166
8A-1	2/17/18	1 ¾	280
8A-2	2/17/18	1 ¾	280
8A-3	2/17/18	1 ¾	280
8A-4	2/17/18	1 ¾	280
6A-1	2/17/18	1 ¾	280
6A-2	2/17/18	1 ¾	280
7A-1	2/17/18	1 ¾	280

Deck transverse tendons were post-tensioned on February 8 and 9, 2018.

Results of concrete tests performed by Universal Engineering Services of Medley, FL, of the samples taken on October 18, 2017 (first pour for the deck), November 6, 2017 (Pour 2 for the diagonals), and December 14, 2017 (Pour 3 for the canopy) indicated satisfactory strength at or above 8,500 psi. Reproduced below is a representative data.



**UNIVERSAL  
ENGINEERING SCIENCES**

Consultants In: Geotechnical Engineering • Environmental Sciences  
Geophysical Services • Materials Testing • Threshold Inspection  
Building Code Administration, Compliance Inspection & Plan Review

9960 NW 116th Way, Suite 8, Medley, FL 33178 - P: 305.249.8434 - F: 305.249.8479

Project No: 2110.1600128.0000  
ReportNo.: 260254-1 CT 110617  
WorkorderNo.: 260254  
Lab No.: 18A751-C

**Compressive Strength of  
4" x 8" Cylinder Test Specimens  
(ASTM C-39)**

Client MCM Corporation  
6201 SW 70th St. 2nd Floor, Miami, FL 33143

Project FIU Pedestrian Bridge - CQC  
109th Ave SW 8th St., Miami-Dade County, FL 33199

Structural Element: Truss System

Sample Location: FIU Pedestrian Bridge - Sampled at Truss system 2 of 12 of the Main Span - CC6A007Q

Set# 1 of 5 Sample From: Concrete Truck Sample By: Client Cast on 11/06/2017 At Lab On or Before: 03/15/2018

General Information		Specified Strength / Sampling Times		Placement Information	
General Contractor: MCM	Subcontractor:	Specified Strength: 8500 psi @ 56 days	Mix Design Strength: 8500 psi @ 56 days	Truck Load: 50.00 cu yds.	Cumulative Quantity: N/A
Supplier: Cemex	Truck No.: 1	Water Added at Site: N/A	Time Batched: n/a	Total Placement for the Day: N/A	
Ticket No.: 35350041	Mix Design: 06-1399	Admixture: N/A	Time Sampled: n/a		
		Weather Condition: Unknown			

**Field Test Results**

Air Content: 1.5 %		Slump: 7.00 inches		Ambient Temp: 81 °F		Concrete Temp: 81 °F		Unit Weight: N/A		
Results of Laboratory Testing										
Test Results	Date Tested	Age Days	Type Of Fracture	Actual Dimen.1 (in)	Actual Dimen.2 (in)	Avg. Dimen. (in)	Test X-Sect. Area (in <sup>2</sup> )	Max Compressive Load (lbs)	Test Compressive Strength(psi)	Average (psi)
1	11/13/2017	7	5	4.00	4.02	4.01	12.63	111,620	8,838	-
2	11/13/2017	7	5	4.03	4.01	4.02	12.69	113,400	8,936	8,890
3	11/20/2017	14	5	4.00	4.02	4.01	12.63	118,900	9,414	-
4	11/20/2017	14	5	4.02	4.01	4.02	12.69	117,420	9,253	9,330
5	12/04/2017	28	5	4.02	4.02	4.02	12.69	118,820	9,363	-
6	12/04/2017	28	5	4.00	4.02	4.01	12.63	118,740	9,401	9,380
7	01/01/2018	56	5	4.01	4.00	4.01	12.63	129,730	10,272	-
8	01/01/2018	56	5	4.02	4.02	4.02	12.69	127,090	10,015	-

To establish a mutual protection to Universal's clients, the Public and ourselves, all reports are submitted as confidential property of our clients and authorization for publication of statements, conclusions or extracts from or regarding Universal's reports is reserved pending our written approval.

Revised May 2016

Figure 14 Concrete testing report

**5. Peer review:**

Florida DOT classified the FIU pedestrian bridge as a Category 2 bridge. FDOT requires that “for all category 2 bridges, an independent peer review is required”. FDOT further states that “the peer review is intended to be a comprehensive thorough independent verification of the original work. An independent peer review is not simply a check of the EOR’s plans and calculations, it is an independent verification of the design using different programs and independent processes than what was used by the EOR.” (See chapter 26 entitled “Bridge Project Development” of the Plans Preparation Manual Volume 1 revised January 1, 2014).

FIGG selected the Louis Berger Group to conduct the required peer review of their design of foundation, sub-structure and super-structure. FIGG had the authority to select any consultant from the approved Florida DOT list of consultants to perform the peer review. Louis Berger prepared its own scope of work on September 13, 2016, after negotiations and discussions with FIGG regarding the consulting fees Louis Berger would charge FIGG for the peer review, and the time frame in which the review needed to be completed. Louis Berger’s involvement began in August 2016 and ended in February 2017. The following is the “independent Peer review scope” prepared by Louis Berger.

**Independent Peer Review Scope**

1. Louis Berger will perform Independent Peer Review for the concrete pedestrian bridge plans in accordance with the project and RFP requirements and FDOT Plans Preparation Manual (Chapter 26).

2. The Independent Peer Review will include the following activities:

Item #	Item Description
1	Develop finite element model for the bridge and estimation of demands on all elements due to different load combinations
2	Peer review of foundation plans
3	Peer review of substructure plans
4	Peer review of superstructure plans

3. The Independent Peer Review will be performed for the following submittals:
  - a) Final Foundation and Substructure Plan Submittals
  - b) Final Superstructure Plan Submittals

4. This Independent Peer Review scope of work is for the pedestrian bridge structure components only. The elevator structures and stairways/landings are not included in this scope of work.

Louis Berger employed Adina, a commercially available software, to analyze the structure in accord with the FDOT requirements that the reviewer use software other than the ones used by the designer. FIGG had used software, Larsa 4D and Lusas. In the Adina analysis, Louis Berger did not use solid elements or rigid links between the members. However, reasonable results could be expected even without using solid elements and rigid links. Louis Berger discovered during the review of the design at the final completion stage of the structure that Member 1 was subject to excessive bending moments. FIGG agreed, and introduced a couple of hinges in Member 1 to alleviate the bending moments. Louis Berger also raised the issues of excessive compressive stresses in Member 2 due to post-tensioning of the PT bars. FIGG explained to Louis Berger that the post-tensioning is required during the movement phase to counter the tensile forces in the diagonal due to cantilever action during the transportation. After the main span was transported and seated on the piers, the PT bars would be de-tensioned. Louis Berger had no other significant comments. OSHA asked Louis Berger repeatedly to provide the peer review computations, and emails between Louis Berger and FIGG during the peer review. It is regrettable that Louis Berger did not respond to OSHA's request.

Unfortunately, Louis Berger did not examine the structural design of the main truss during intermediate stages of construction when the main span truss would be placed on the piers without the advantage of the back span and intermediate pylon, a condition that existed from March 10 through March 15, 2018. Louis Burger considered the truss to be continuous spanning over the main span and the back span with pylons and the pipe supports completed. The forces in the truss members, in particular the members near the north pylon, would be significantly different when the truss is continuous compared to the truss as simply supported on the south pier and north pylon. Louis Berger explained to OSHA that they were contracted to only do the final check and not the design check at intermediate stages. FIGG did not follow the FDOT requirements of peer review at 30%, 60% and 90% of completion of the construction documents. If Louis Berger had checked the design at Stage 3, it could have discovered structural

deficiencies in the design, and this incident could have been prevented. An opportunity was missed. Louis Berger and FIGG did not comply with the intent and meaning of the FDOT provisions of the peer review.

Louis Berger provided three certificates of peer review to FIU: on September 13, 2016, for the 100% Bridge Foundation Plans; on September 29, 2016, for the 100% Bridge Substructure Plans; and on February 10, 2017, for the 100% Bridge Superstructure Plans. All three certificates contained the following passage:

*Pursuant to the requirements of the Contract documents, Louis Berger hereby certifies that an independent peer review of the above-referenced submittal has been conducted in accordance with Chapter 26 of the Plans Preparation Manual and all other governing regulations.*

During an interview with OSHA, the Louis Berger engineer who performed the peer review stated that the magnitude of consulting peer review fees and time to conduct the peer review were rather constrained, and had an impact on the peer review. The entire review was conducted by one engineer without any assistance from others at Louis Berger. It is interesting to note that neither FIGG, FIU nor FDOT raised the issue of why the structural design of the intermediate stage was not checked by Louis Berger. FIU and FDOT may not have known that the intermediate stages of construction were not checked by Louis Berger, but FIGG knew because Louis Berger created the scope of work based on the limited resources allocated by FIGG.

The structural engineer from the Louis Berger Group who conducted the peer review said, during interview with OSHA, that four months after the completion of the peer review, he was no longer working for Louis Berger due to unrelated reasons.

## **6. The cracks**

Cracks developed soon after the shoring was removed from under the truss structure.

February 26, 2018      Photographs of the cracks were taken by BPA.

February 28, 2018      BPA forwarded the photos of cracks to MCM asking for response from FIGG, as cracks needed “special attention.”

MCM forwarded the photos of cracks to FIGG.

The photographs are duplicated below in Figure 15 through Figure 20.



Figure 15 Photo #1 in 2/28/2018 E-mail from MCM to FIGG





Figure 16 Photo #2 in 2/28/2018 E-mail from MCM to FIGG



Figure 17 Photo #3 in 2/28/2018 E-mail from MCM to FIGG



Figure 18 Photo #4 in 2/28/2018 E-mail from MCM to FIGG



Figure 19 Photo #5 in 2/28/2018 E-mail from MCM to FIGG



Figure 20 Photo #6 in 2/28/2018 E-mail from MCM to FIGG

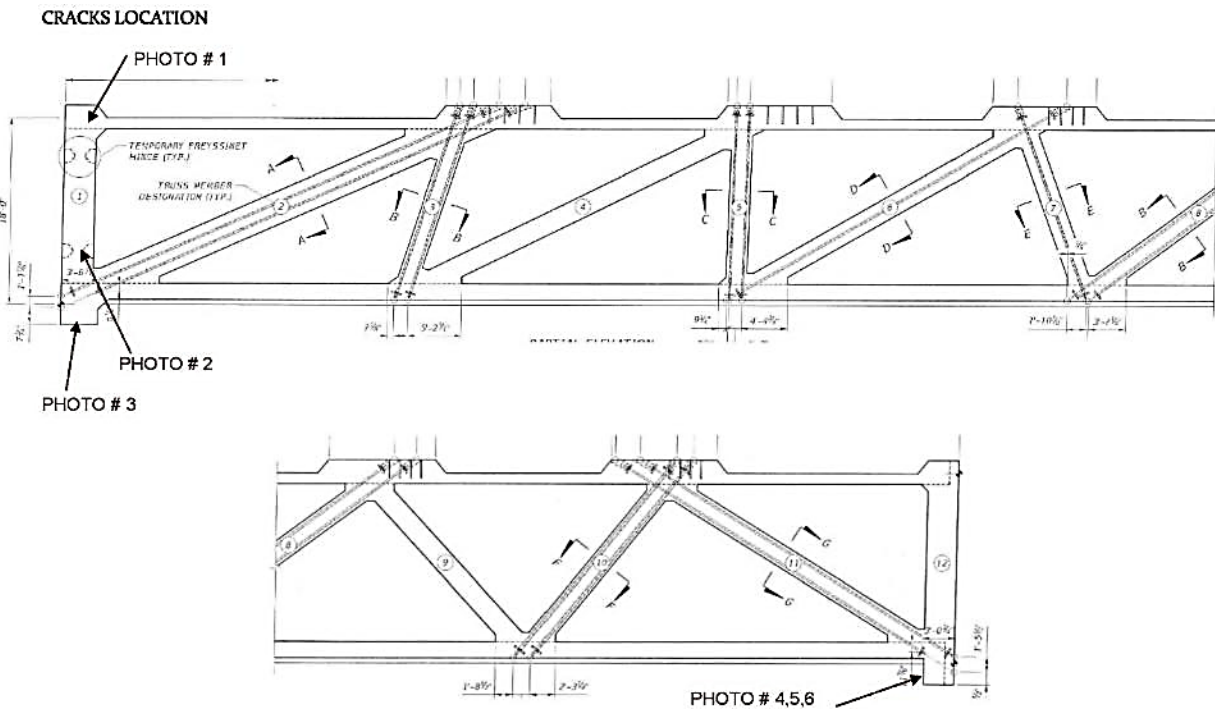

Figure 21 Location of cracks in 2/28/2018 E-mail from MCM to FIGG as per BPA

March 7, 2018

FIGG responded to the photos of cracks with the following comments:

Photo 1 (Figure 15): No structural concern.

Photo 2 (Figure 16): Cracks expected.

Photo 3 (Figure 17): No concern.

Photos 4, 5 and 6 (Figure 18, Figure 19 and Figure 20): Cracks developed at diagonal 11 and its bottom chamfer. No concern expressed by FIGG. FIGG anticipated that “MCM will seal these cracks in accordance with FDOT Standard Specifications.” These cracks were, however, never sealed.

A pre-movement meeting was held at 3:00 PM attended by FIGG (3 employees), FIU (2 employees), MCM (2 employees), BPA (4

employees), Corradino (one employee), and Barnhart (3 employees). Detailed discussion between the participants occurred.

March 10, 2018 Truss was transported by SPMT and placed on the pier and the pylon, and were generally free of cracks other than those mentioned above, and as shown in the following pictures.



Figure 22 North end of the main span truss during transportation, generally free of cracks

VSL mobilized the crew and began the preparation to de-stress the PT bars in diagonal 2 and 11 as the post-tensioning of diagonal 2 and 11 was required only during the movement. First, PT bars in diagonal 2 were de-stressed and then the crew proceeded towards diagonal 11. As they began to de-stress the PT bars of diagonal 11, cracks began to appear at multiple locations, most prominently at the construction joint of diagonal 11 and the

deck and at the top of the diaphragm II. There were three VSL employees performing the de-stressing – Kevin Hanson (supervisor), Navarro Brown and Chester Ashley. Kevin is regarded as one of the most knowledgeable PT field personnel in South Florida. After observing the cracks, Kevin became visibly disturbed and informed other VSL employees of the situation. Kevin took pictures of the cracks, and sent them to his supervisor, Sam Nunez, stating that “it cracked like hell”, see Figure 23. Reproduced below is Kevin’s text. Ashley mentioned to OSHA that Kevin went to MCM to show the photos of the cracks. Sam Nunez of VSL stated during an OSHA interview that the photos he received subsequent to March 10 were different, showing spalling and cracks in the diaphragm II implying that additional cracks took place after March 10, 2018.

In a March 22, 2018 interview with OSHA, MCM superintendent, Ernesto Hernandez, stated that Kevin Hanson told Pedro Cortes (MCM in charge of quality control) that cracks were appearing at the bottom of diagonal 11 after de-stressing. Mr. Cortes examined the cracks and took pictures on March 10, 2018.



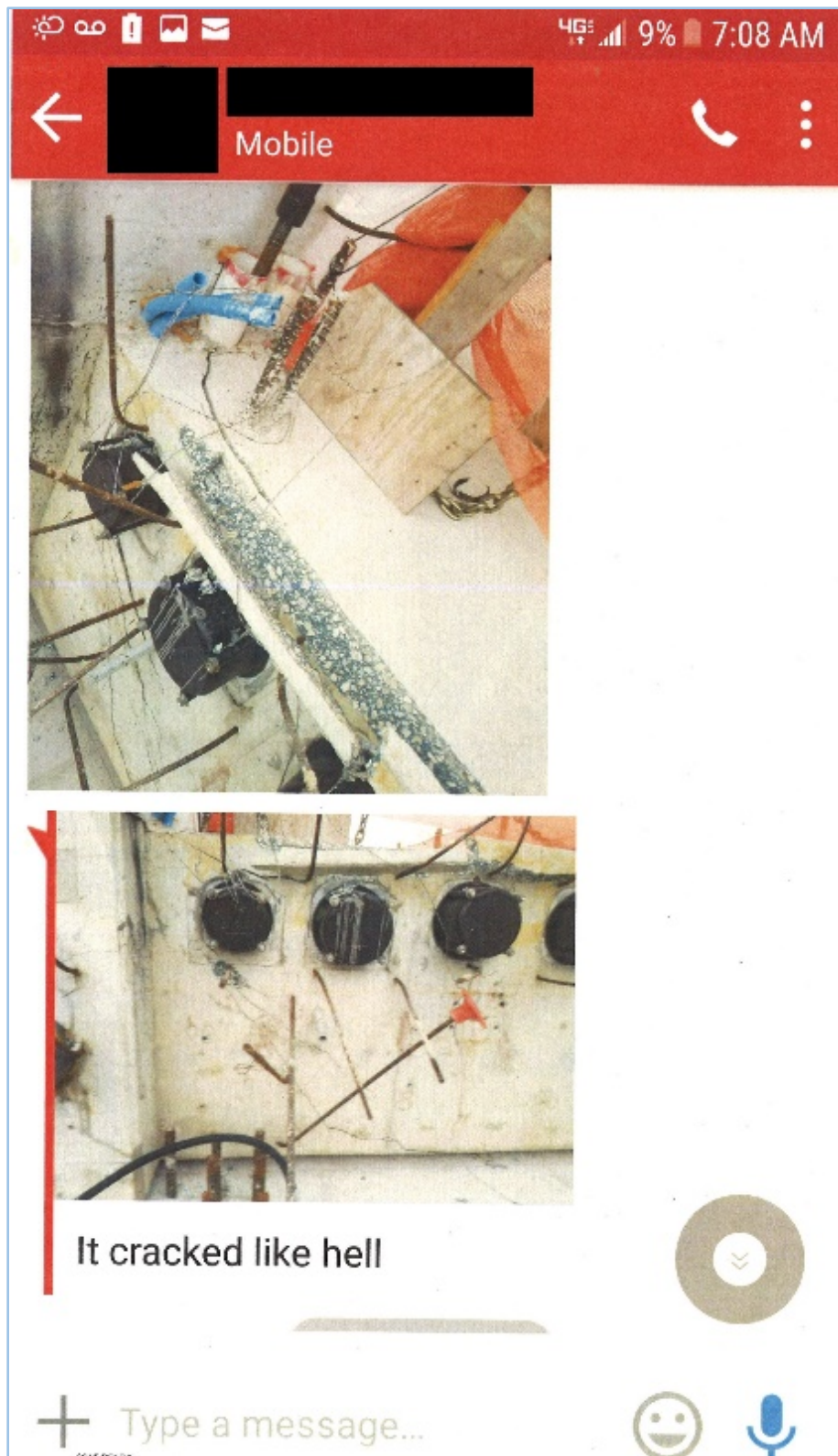

Figure 23 Screenshot of Kevin Hanson's message to Sam Nunez on March 10, 2018

March 12, 2018

MCM employees, Ernesto Hernandez, and Pedro Cortes took pictures of the cracks. At 4:51 pm, MCM Senior Project Manager, Rodrigo Isaza, sent an email to Dwight Dempsey, PE of FIGG, with copies to other engineers (Denney Pate, Franklin Hines, Eddy Leon, and Manuel Feliciano) of FIGG asking them to comment and review the pictures of the cracks as promptly as possible. Mr. Isaza had a sense of urgency, and opined that **“some of these cracks are rather large and/or of concern”** (emphasis ours). MCM stated “your immediate attention and response is required.” Ernesto Hernandez, MCM superintendent, on March 22, 2018 during an OSHA interview stated that Cortez, MCM quality control, went back to see the cracks and told him that “the cracks had increased.” Mr. Hernandez went himself to look at the cracks and that “the cracks had gotten wider and larger.”

The pictures sent to FIGG, and some additional pictures of the cracks are reproduced below:



Figure 24 Cracks at the west side diaphragm II MCM email of 3/12/2018 – top face, by BPA.



Figure 25 Cracks at the west side diaphragm II MCM email of 3/12/2018, by BPA – side face



Figure 26 Cracks at the east side diaphragm II MCM email of 3/12/2018, by BPA – top face



Figure 27 Cracks on the east side diaphragm II MCM email of 3/12/2018, by BPA – side face

March 13, 2018

As the email was sent by MCM in the evening of March 12, 2018, FIGG did not open MCM's email containing the photos of the cracks until the next morning on March 13, 2018 around 8:30 am. After discussions among engineers, FIGG asked MCM at around 9:45 am to put an additional plastic shim "right away" similar to the existing shims on the pylon directly under the diaphragm. FIGG stated that no jacking of the bridge is required. FIGG also stated in the email that "since Saturday (March 10, 2019) afternoon MCM has been monitoring the cracks and they have not grown in size." FIGG directed that the shim must be placed tight against the top and bottom surface. The idea, as per FIGG interview with OSHA, was to replicate the condition that existed in the casting yard where the truss was self-supporting from February 28 until March 10 without developing any cracks other than what FIGG termed as shrinkage or hairline cracks. But FIGG failed to consider that the diaphragm II was laterally braced in four directions in the casting yard by pipe braces providing considerable lateral support to diaphragm II. FIGG did not ask MCM to provide similar lateral braces to diaphragm II to replicate the casting yard conditions.

At approximately noon time, MCM emailed to FIGG "Moreover, we will be monitoring the cracks to ensure these do not develop further."

Denney Pate of FIGG called FDOT on a landline and left a message saying that cracks have been observed on the north side of the bridge, and repairs were needed but there were no safety concerns. The message was not heard until the day after the incident as the FDOT employee was out of town on assignment.

At 5:18 pm, FIGG confirmed that "again, we have evaluated this further and confirmed that this is not a safety issue." FIGG gave additional instructions to MCM to re-tension the two PT bars in diagonal 11 to 280 kips each stressing the two bars alternately to 50 kips each at a time until

the full tension of 280 kips is achieved. FIGG was concerned about the increase in crack size. It stated “the type II diaphragm should be closely monitored during the PT bars stressing process to ensure that the crack size does not increase.” FIGG stated that “FIGG recommends to stress those PT bars as soon as possible but again, this is not a safety concern.” FIGG hoped that the re-tensioning would either stop further growth of the cracks, or shrink the crack sizes. FIGG further instructed MCM to stop re-tensioning and immediately notify FIGG if the cracks increased in size, and that re-tensioning needed to occur as soon as possible. VSL crew had moved out of the town and could not report to the site until March 15, 2018, with a crane to assist in re-tensioning.

Some Photographs of the cracks taken on March 13, 2018, and March 14, 2018, are reproduced as follows:





Figure 28 Diagonal cracks on the west side of diaphragm II on 3/13/2018, by BPA – top face



Figure 29 Close-up of cracks at the west side of diaphragm II on 3/13/2018, by BPA



Figure 30 Notice the depth and width of diagonal cracks at the west side of diaphragm II on  
3/14/2018 by BPA



Figure 31 Notice the depth and width of cracks near column 12 at the west side of diaphragm II  
on 3/14/2018 by BPA



Figure 32 Cracks at the construction joint of the main span deck and diagonal 11 on 3/13/2018 by BPA



Figure 33 Cracks at the construction joint of the main span deck and diagonal 11 on 3/13/2018 by BPA



Figure 34 Cracks at the construction joint of the main span deck and diagonal 11 on 3/13/2018 by BPA



Figure 35 Cracks at the construction joint of the main span deck, diagonal 11 and the chamfer of diagonal 11 on  
3/13/2018 by BPA





Figure 36 Cracks at the construction joint of the main span deck and diagonal 11 on 3/13/2018 by BPA



Figure 37 Cracks at the construction joint of the main span deck and diagonal 11 on 3/13/2018 by BPA



Figure 38 Cracks at the construction joint of the main span deck and diagonal 11 on 3/13/2018 by BPA



Figure 39 Close-up of longitudinal cracks in diagonal 11 on 3/14/2018 by BPA



Figure 40 Close-up of longitudinal cracks in diagonal 11 on 3/13/2018 by BPA



Figure 41 Close-up of longitudinal cracks in diagonal 11 on 3/13/2018 by BPA



Figure 42 Cracks at the west side of diaphragm II on 3/14/2018 by BPA

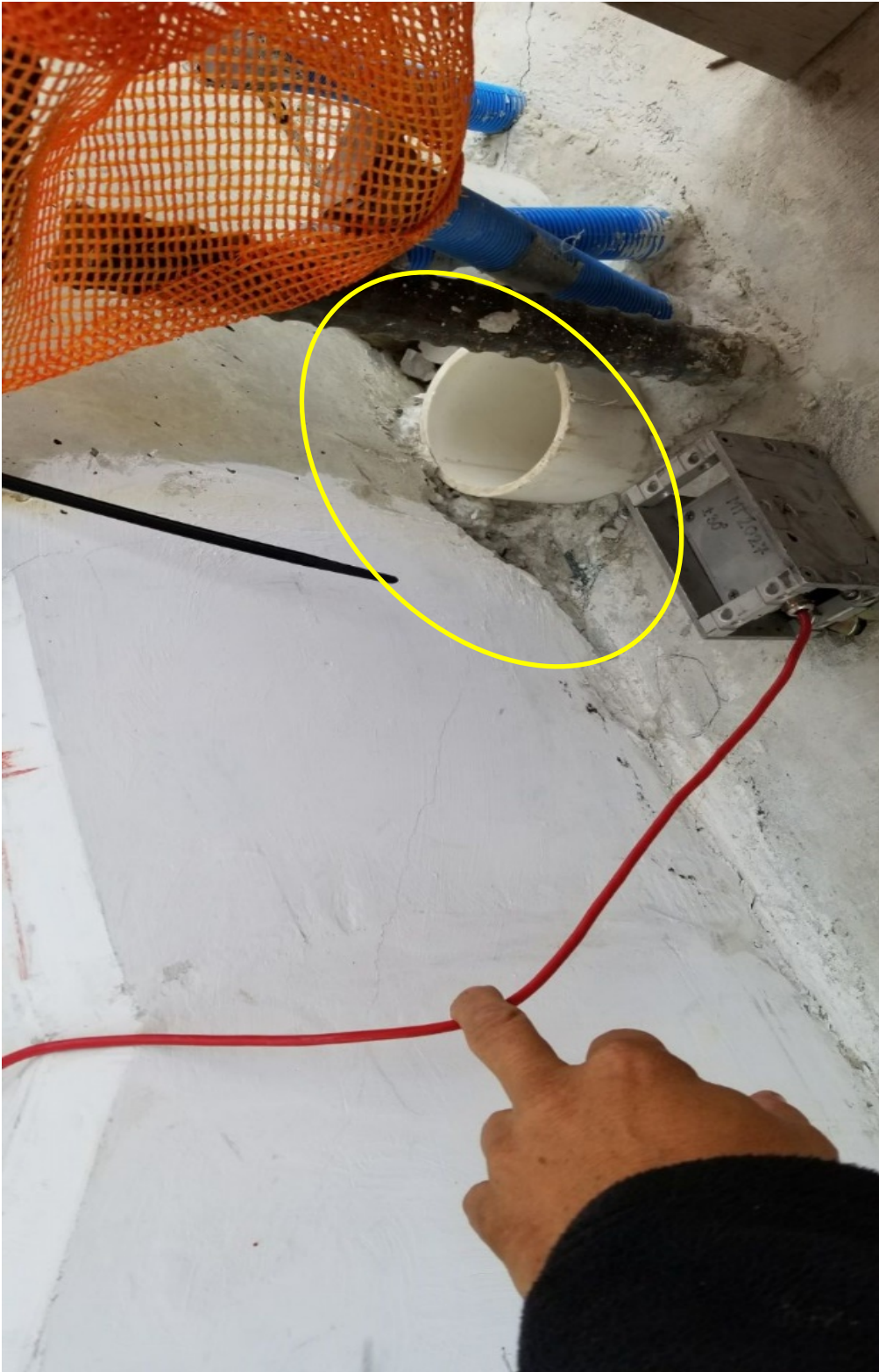

Figure 43 Cracks at the east side diaphragm II on 3/10/2018 – top face, by Corradino





Figure 44 Cracks and movement of the column at the east side of diaphragm II on  
3/14/2018 by BPA

March 14, 2018

MCM sent additional pictures of the cracks to FIGG.

MCM confirmed meeting with FIGG for March 15, 2018, for FIGG to present its findings on the cracks and discuss remedial measures to a team consisting of FIU, FDOT, MCM and BPA. MCM had another opportunity to inform FIGG that the crack sizes had been increasing since Saturday (March 10, 2018) as reported by its own employees Pedro Cortes and Ernesto Hernandez. On March 22, 2018, Ernesto Hernandez in an OSHA interview stated that he and Pedro Cortes went up to the bridge on March 14, 2018 and saw that “the cracks were getting larger.” He asked Rodrigo Isaza “what could be causing the cracks?” Rodrigo said “I wish I could tell you.” MCM should have immediately informed EOR on March 14, 2018 of its findings. Despite this oversight on the part of MCM, FIGG was provided with photographs and measurements of the cracks in the days leading up to the collapse and was, specifically informed by BPA during the morning meeting on March 15, 2018, that the cracks were lengthening.

FIGG spent the day at its office analyzing the cracks as they appeared on the photographs provided by MCM and prepared for the presentation the following day.

MCM and TSG placed the recommended shim (steel instead of plastic) under the diaphragm II. VSL, who was concerned about the cracks and wanted FIGG to analyze them to determine if an epoxy could be used, asked MCM if the cracks would be fixed before re-tensioning the PT bars in diagonal 11. MCM responded in the negative because of FIGG’s assurance that the cracks did not present any safety issues. MCM instructed VSL to proceed with the preparation to re-tension PT bars in diagonal 11. MCM arranged a crane to be present on March 15, 2018, to facilitate re-tensioning.

March 15, 2018

Two structural engineers from FIGG, Denney Pate and Eddie Leon arrived at the site approximately 7:45 am to examine the cracks first by walking over the deck. Thereafter, they evaluated the cracks by using a man-lift for better access. Also present were MCM's Rodrigo Isaza and Pedro Cortes, and BPA's Jose Morales. Denney Pate and Pedro Cortes went up in a man-lift, and examined the cracks. It was reported to OSHA during an interview that Denny Pate said that the cracks looked worse than in the pictures.

At approximately 9 am, a meeting was held in MCM's trailer with the attendees from FIGG, FIU, MCM, FDOT and BPA. FIGG was to present its findings and recommendations to the group on the cracks on the north side of the bridge. BPA informed OSHA that BPA prepared the minutes a couple of days after the meeting based on handwritten notes taken by BPA during the meeting. BPA also told OSHA that BPA sent the minutes to all participants of the meeting on March 20, 2018, for any comments or edits. BPA said that they received no comments from any of the participants, and therefore the minutes prepared by BPA became final. However after an interview with OSHA, FIGG provided its own version of the meeting, labeled as "corrected".

FIGG presented the following premise to the attendees. (They have been paraphrased by us).

1. The cracks do not present any safety concern as per FIGG's evaluation.
2. This is a temporary loading condition during construction until the intermediate pylon and back span truss are completed.
3. MCM must expedite pouring of intermediate pylon and construction of back span truss.
4. After the construction of the back span, the structural behavior of main span would change and forces in diagonal 11 and the node at 11/12

will be reduced. The intermediate pylon and back span will be integrated with the existing diaphragm II and the main span, and the reserve strength will be increased.

5. “The spalled areas have not been replicated by the engineering analysis.” (quote)
6. “The spalled areas are minor.” (quote)

FIGG did not know the reason for the cracks, but still expressed no safety concerns. However, FIGG in its presentation alluded to a lingering concern about the structural inadequacy of the 11/12 node until the intermediate pylon and back truss were completed. FIGG mentioned a “temporary mechanism to capture the nodal zone”. FIGG opined that it may be “appropriate to transfer some of the load off 11/12 node.” FIGG was to consider options to “capture some of the forces from the node”. FIGG also stated that “prudent action is to share some of the load carried back to 9/10 and construct pylon diaphragm”. FIGG further proposed to “restrain” the node. FIGG promised to deliver the temporary mechanism to capture the forces and node 11/12 by March 17, 2018 to MCM in two days, showing a sense of urgency.

FIGG rightly recognized the structural inadequacy of node 11/12, and presented remedial measures to “capture the loads”, “restrain the node” and “share some of the loads” to the node 9/10. But at no time did FIGG recommend the shoring of the bridge at intermediate locations of the span to reduce loads in diagonal 11 and nodal zone 11/12 and closure of SW 8th Street until the proposed remedial actions were evaluated and implemented, thus exposing its own employees and employees of other entities to danger. That was an error on FIGG’s part. The street closure was warranted due to the inadequacy of the node to support the loads during Stage 3, until all the remedial measures were designed, evaluated, peer reviewed and implemented or until the intermediate pylon was

constructed. FIGG also very well knew that the truss was a non-redundant structure, and failure of diagonal 11 could result in the collapse of the bridge. FIGG knew that the Louis Berger Group, the independent consultant assigned to conduct the peer review of the bridge, did not perform independent design check of construction stage 3, i.e. the stage in which the truss collapsed.

As per the minutes of the meeting recorded by BPA/FIU, BPA asked if FIGG's analyses were peer reviewed, and stated that "the more eyes on this, the better". FIGG agreed. The analysis conducted by FIGG from March 12-14 was not, in fact, peer reviewed. FIGG presented the findings without the advantage of another set of eyes of an independent consultant. Please see, "Peer review" earlier in the report. FIGG knew that the engineer who performed the peer review did not check the bridge design during different stages of construction, in violation of the FDOT requirements. This made it all the more critical to conduct a peer review of FIGG's latest analyses and recommendations. Even FIGG's recommendation of re-tensioning the PT bars of diagonal 11 was not peer reviewed. FIU, FDOT and MCM did not insist that all computations performed by FIGG, including FIGG's recommendation to re-tension the PT bars be peer reviewed. They deferred to FIGG's conclusions, and failed to apply their own judgement and judiciousness, even though FDOT, BPA and MCM have extensive experience in bridge and concrete construction.

FIGG during its interview with OSHA, claimed that there was no change in cracks from March 10 through March 14. In fact, the cracks were expanding every day. In the meeting on the morning of the collapse, BPA informed MCM that the cracks were expanding in length, as recorded by BPA in the minutes from the meeting on March 15, 2018. We reproduce below the item in the minutes of the meeting as prepared by BPA.

*MCM to BPA: Have the cracks increased in length or depth?*

*BPA confirmed cracks have **increased in length daily** (emphasis ours).*

In FIGG's "corrected" version of the meeting minutes, there is no mention of the above item. Instead, FIGG's version stated that FIGG asked "if there were any changes in the cracks. BPA, CEI and MCM confirmed only small changes."

FDOT STRUCTURE specifications 400-21.3 "Classification of Cracks" states that the engineer (BPA) will classify cracks as either nonstructural or structural, and determine the cause. In general, nonstructural cracks are cracks ½" or less deep from the surface of the concrete; however the engineer may determine that a crack greater than ½" deep is nonstructural. In general, structural cracks are cracks that extend deeper than ½". The pictures indicate the cracks to be deeper than ½" to the order of 3", 4", or 7", see Figure 30, 31, 39 and 42.

FDOT Specifications 400-21.5.2 Structural Cracks: "Provide a structural evaluation signed and sealed by the contractor's Engineer of Record that includes recommended repair methods and a determination of structural capacity and durability to the Engineer".

FIGG during the interview with OSHA stated that not all the pictures of the cracks were sent to them by MCM but regardless, FIGG engineers personally examined the cracks on the morning of the collapse, March 15, 2018, in a man-lift taking a close view of the intensity and magnitude of all the cracks on the deck and the diaphragm. Prior to viewing the cracks in person on March 15, 2018, FIGG received relevant pictures of the cracks, some of which they included in their PowerPoint presentation. On the morning of the collapse, FIGG should have witnessed the slip and movement at the construction joint between diagonal 11 and the deck, and also witnessed the diagonal shear cracks at the top of the diaphragm II on both sides of the column 12 proceeding from the location of the insert pipes to the location of the first tendons D1. FIGG should have also noticed that the cracks were getting longer, wider and deeper compared to the pictures of the cracks they had seen earlier. The cracks on the east and west sides of the top of the diaphragm were identical, both emanating from the 4" dia. pipe, a weak point in the diaphragm. The immediate action for FIGG should have been to take the following steps to significantly reduce the loads in diagonal 11.

- (i) Rescind the instructions to MCM to re-tension the PT bars in diagonal 11.

- (ii) Recommend closing SW 8th Street, and shore the truss at appropriate locations.
- (iii) Determine the cause of the cracks.
- (iv) Perform re-evaluation of its design of the north end with an independent peer review.
- (v) Prepare remedial measures.
- (vi) Prepare a structural evaluation report signed and sealed by FIGG in accord with FDOT specifications 400-21.5.2.

The above were all the more significant because FIGG should have known that this is a non-redundant structure, and in the event one diagonal failed the entire truss could collapse. Experienced structural engineers such as the ones at FIGG should have concluded that the bridge was in danger of collapse, and should have taken the necessary steps enumerated above. Moreover, FIGG should also have known that independent peer review had not been done for the structural integrity of the main truss during stage 3 in violation of the FDOT requirements. Additionally, FIGG was informed by BPA in the presentation meeting of March 15, 2018, that the cracks were lengthening. That was in contradiction of the assumption FIGG made to perform the evaluation. FIGG performed the evaluation on March 13 and 14, 2018 on the premise that the cracks were not lengthening. The expansion of the cracks could have been obvious by comparing the pictures of March 12 and 13, 2018 to what they actually witnessed on the morning of March 15, 2018. Moreover, BPA's statement that the cracks were lengthening should have been a catalyst for FIGG to take immediate steps as described above.

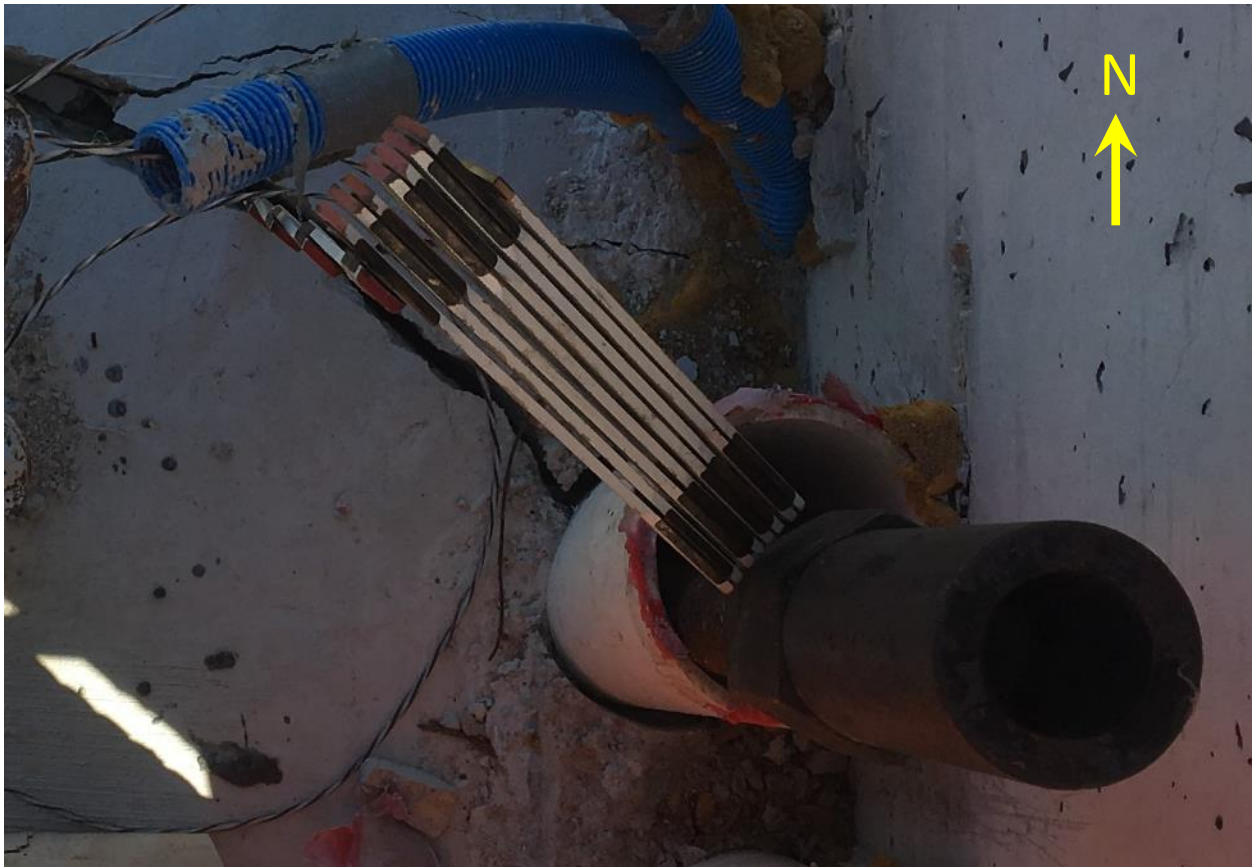

Figure 45 Note the gap indicative of movement between sleeve pipe and concrete, pictured on 3/13/2018 by BPA

### BPA

After the meeting was over, BPA as a Construction Engineering and Inspection (CEI) contractor should have applied its own professional independent judgment regardless of the opinion expressed by FIGG by immediately asking FIU and MCM to postpone the re-stressing of the PT bars in diagonal 11 and shore the truss at appropriate locations by closing SW 8<sup>th</sup> street until such time that FIGG determined the cause of the cracking and prepare remedial measures. BPA knew that FIGG was unsure of the structural integrity of the north node. BPA also knew that the truss is a non-redundant structure. FIU's scope of work with BPA is as follows:

*The Consultant shall exercise its **independent professional judgment** in performing its obligations and responsibilities. (Emphasis ours.) Pursuant to Section 4.1.4 of the*



*Construction Project Administration Manual (CPAM), the authority of the Consultant's lead person, such as the Consultant Senior Project Engineer and the Consultant Project Administrator, shall be identical to the Department's Resident Engineer and Department Project Administrator, respectively, and shall be interpreted as such. Similarly, the Consultant Senior Project Engineer and the Consultant Project Administrator shall be identical to the FIU Construction Project Manager.*

FDOT requirements for CEI's is reproduced below:

*"...CEI firms shall be allowed to exercise their **independent professional judgement** (Emphasis ours.)...The role of the Department's Project Manager (PM) is to ensure that these CEI firms are providing services in accordance with their Contract and not controlling the means and methods by which the CEI firm performs these services. Department procedures allow review and rating of such services and further provides for recovery of any errors and omissions made by the CEI firm."*

*Jose Abreu*

*Secretary of Transportation*

*February 6, 2004*

## FDOT

FDOT had no construction supervision role in the project as the bridge was essentially owned by FIU. FDOT, however, had the authority to grant permission to close the SW 8<sup>th</sup> street when requested by FIU and its design-build team as the 8<sup>th</sup> street was a State Road.

The March 15, 2018 meeting was attended by a representative of FDOT, Mr. Alfredo Reyna, PE. Mr. Reyna is a professional engineer licensed to practice in the State of Florida. He is a graduate of FIU with degrees in civil and mechanical engineering graduating approximately 33 years ago, but he is not a structural engineer. Mr. Reyna is a LAP coordinator for FDOT District 6, and a consultant to FDOT. Mr. Reyna is

employed by Keith and Schnars, Consulting Engineers under contract with FDOT. Mr. Reyna's involvement in the FIU project was not peripheral as he is reported to have attended all weekly and monthly conference calls between FIU and FDOT. He is reported to have worked closely with FIU and BPA. His involvement in the project began with FDOT review process of FIGG drawings. The review was essentially conducted by FDOT Structural Group but Mr. Reyna was aware of the many comments made by FDOT during the review process.

In the March 15, 2018 meeting, Mr. Reyna was an active participant as per BPA and FIGG versions of the minutes of the meeting. Reproduced below are the two interaction between Mr. Reyna and FIGG.

**FDOT to FIGG: FDOT requests a copy of FIGG's analysis presentation to give to their structural group**

**FDOT to FIGG: Are you going to continue to figure out why it happened?**

- **FIGG responded that all we "know is that it just happened"**

Mr. Reyna was therefore fully aware that FIGG did not know why the cracks were taking place, and still FIGG claimed that the bridge structure had no safety issues. FIGG's presentation included the pictures of the cracks as shown in Figure 24 thru 26. Mr. Reyna also knew that the re-tensioning of the diagonal PT bars were taking place in the afternoon, the same day. As a licensed professional engineer, it is reasonable to expect that Mr. Reyna would recommend to MCM and FIU to hold all work including re-tensioning of the PT bars until the measures recommended by FIGG were reviewed by FDOT structural group in Tallahassee, and FIGG determined the cause of the cracks. Mr. Reyna did call the Tallahassee structural group soon after the meeting was over but the person he called was not available.

## 7. The collapse

The de-stressing of the PT bars in diagonal 2 and 11 was completed on March 10, 2018, at approximately 6 pm. Denney Pate of FIGG and other engineers from FIGG had already departed approximately noon to head back to Tallahassee.

FIGG instructed MCM on March 13, 2018, to place an additional shim under the diaphragm II after reviewing and evaluating the pictures of the cracks sent by MCM to FIGG on March 12, 2018. FIGG instructed MCM to re-tension the PT bars in diagonal 11. VSL asked MCM to have FIGG evaluate the cracks and to determine whether the repairs of the cracks needed to be made prior to re-tensioning. MCM responded to VSL that FIGG instructed MCM to re-tension the PT bars now. On March 15, 2018, at the instruction of MCM, VSL gathered its crew and positioned them on the canopy to begin re-tensioning the PT bars in diagonal 11 at approximately noon. The instructions given by FIGG to MCM was to re-tension alternatively the upper and lower bars applying 50 kips alternately to each bar each time until the entire 280 kips tension is achieved. A crane was available at the site to position the jack and attach it to the bar being tensioned. There were three VSL employees – Kevin Hanson (Supervisor), Ramoy Goulbourne and Navarro Brown. In addition, there were two BPA employees – Jose Morales and Carlos Chapman. The sixth person was the MCM employee, Pedro Cortes. VSL employees began re-tensioning the bars around noon and reportedly followed the instructions. They re-tensioned the bars 50 kips at a time alternating between the upper and lower bars. They had re-tensioned the upper bar to the desired tension of 280 kips and were at the lower bar at their last cycle to complete 280 kips when the incident occurred. Mr. Brown was fatally injured in the incident and Mr. Hanson was critically injured. Other employees also sustained injuries.

Diaphragm II experienced a blow-out of concrete at the junction of diagonal 11 and column 12 creating a hole shown below in Figure 58 through Figure 70. As a result, column 12 lost support over the pylon and failed with the top tilting approximately 80 degrees towards the south, as shown in Figure 52. The base of column 12 shifted a few feet towards the north but remained on the top of the pylon. Thereafter, collapse of the canopy, diagonal 11 and the deck followed. The canopy partially remained attached to column 12. The remaining diaphragm II and the deck fell approximately 18 ft. to the ground below, see Figure 52. One end of the diagonal 11 remained

perilously attached to the bottom of the column 12 over the pylon with some rebar, and the other end remained connected to the canopy as shown in Figure 52. As a result of the blow-out, the lower end of the upper PT bar separated from the diaphragm II and rested on the top of the pylon. The lower PT bar of diagonal 11 peeled off from diagonal 11 but remained embedded in the diaphragm. The top ends of the upper and lower PT bars in diagonal 11 remained in the blister. The upper PT bar lost its tension completely and so did the lower PT bar which still carried the Jack used to re-tension the PT bars. The deck laid down approximately 140 feet flat on the ground covering all the four east bound lanes, and three west bound lanes, as shown in Figure 51. The south end of the deck and column 1 were still precariously on the top of the south pier, see Figure 52. The column 1 tilted approximately 15 degrees towards the north with canopy firmly attached. All diagonals other than diagonals 2, 3 and 4 were crushed. The canopy laid flat approximately 80 ft. over the fallen deck. Two blisters on the south side remained intact with the canopy but the rest of the blisters were badly damaged. The blisters at the junction of diagonal 11 and 10 were damaged with the bottom PT bar extending beyond the blister with the ram still attached to the PT bar. As a result of the blow-out, three #7 shear reinforcements at the construction joint of diagonal 11 and the deck were sheared but the southernmost shear reinforcement remained intact. The width of the blow-out was 2 ft. at the southern end gradually enlarging towards the north. The blow-out encompassed the two 4" pipes on either side of column 12, and was symmetrical to the center line of the deck.



Figure 46 Bridge immediately prior to the collapse, March 15, 2018 – camera #1



Figure 47 Bridge immediately after the collapse, March 15, 2018 – camera #1



Figure 48 Bridge immediately prior to the collapse, March 15, 2018 – camera #2



Figure 49 Bridge immediately after the collapse, March 15, 2018 – camera #2  
Employees engaged in re-tensioning the PT bars in diagonal 11





Figure 50 Bridge immediately prior to the collapse, March 15, 2018 – camera #3  
(north on the left and south on the right)



Figure 51 Bridge immediately after the collapse, March 15, 2018 – camera #3  
(north on the left and south on the right)

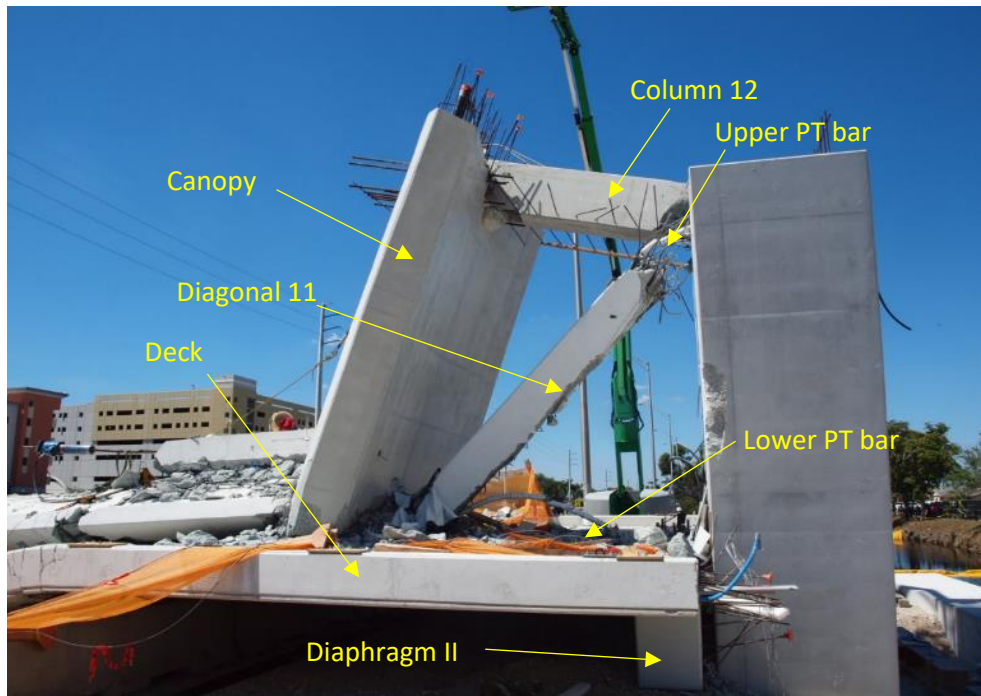

Figure 52 Column 12, diagonal 11 and part of the canopy after bridge deck and diaphragm fell to the ground, March 17, 2018, by OSHA

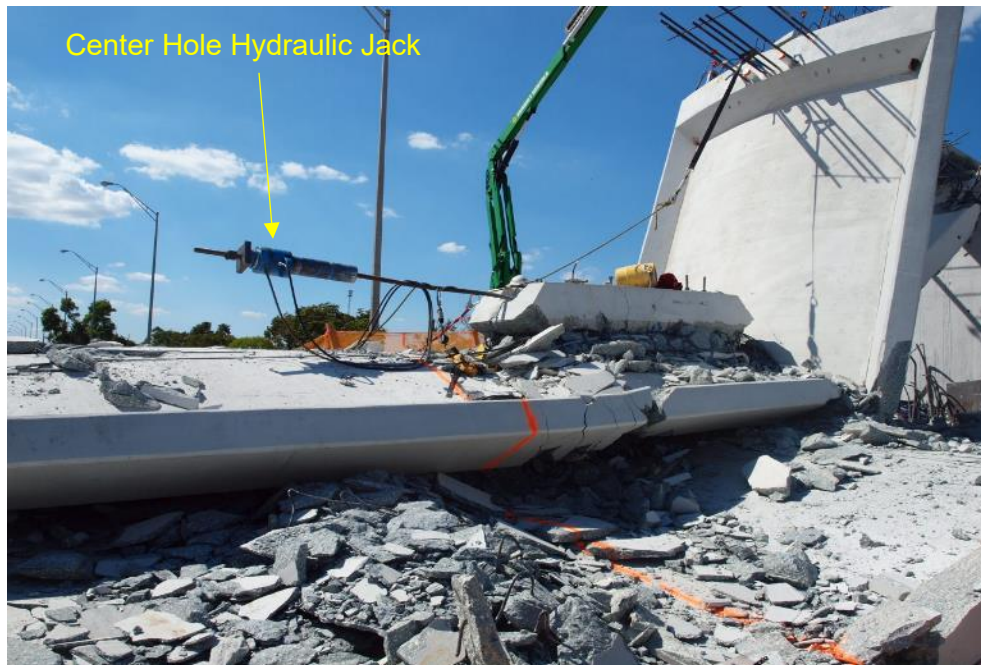

Figure 53 Northernmost blister and hydraulic jack attached to the lower PT bar of diagonal 11 after bridge collapse – side view, March 17, 2018 by OSHA



Figure 54 Northernmost blister and hydraulic jack attached to the lower PT bar of diagonal 11 after bridge collapse – front view, March 17, 2018 by OSHA

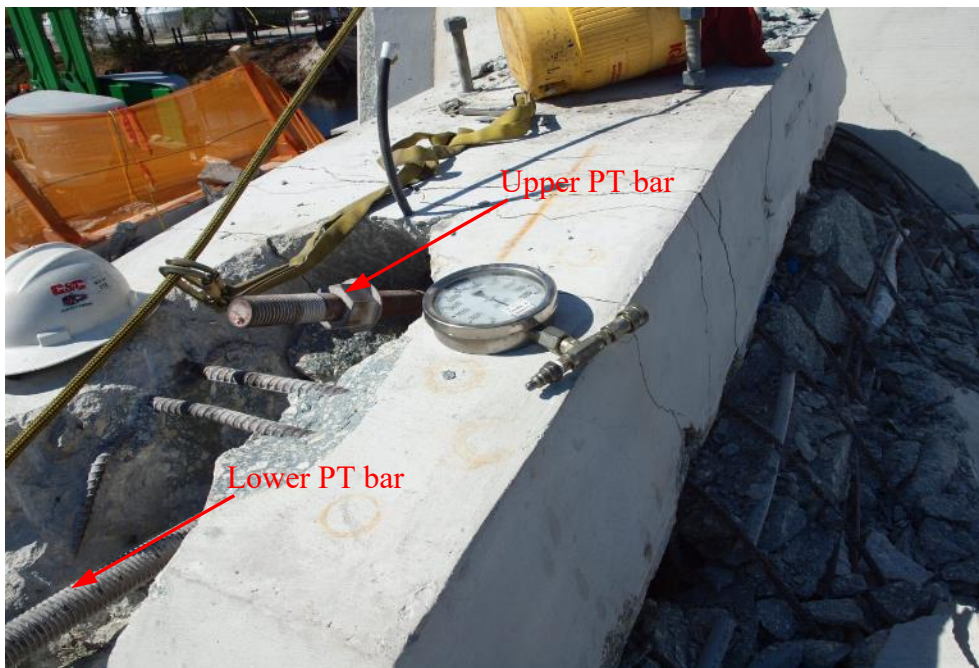

Figure 55 Northernmost blister and pressure gauge, March 17, 2018 by OSHA



Figure 56 Hydraulic pump for post-tensioning after bridge collapse, March 17, 2018 by OSHA



Figure 57 Lower PT separated from the diagonal 11 still embedded in diaphragm after bridge collapse, March 17, 2018 by OSHA



Figure 58 Concrete blow-out failure in Diaphragm II at the time of bridge collapse at the site looking north from south, March 21, 2018, by OSHA



Figure 59 Concrete blow-out failure in Diaphragm II at the time of bridge collapse at the site looking north from south, March 21, 2018, by OSHA



Figure 60 Concrete blow-out failure in Diaphragm II at the time of bridge collapse at the site looking north from south, March 21, 2018, by OSHA



Figure 61 Remnants of diaphragm II at the time of the bridge collapse in the storage yard – looking north from south, April 9, 2018, by OSHA

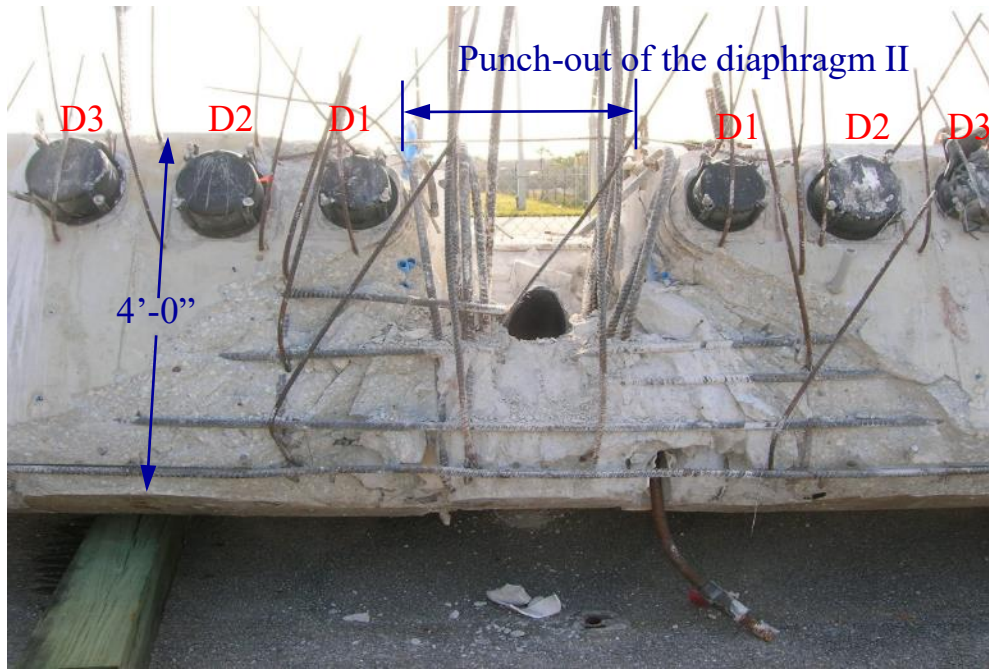

Figure 62 Concrete blow-out failure in Diaphragm II at the time of bridge collapse in the storage yard looking north from south, April 9, 2018, by OSHA

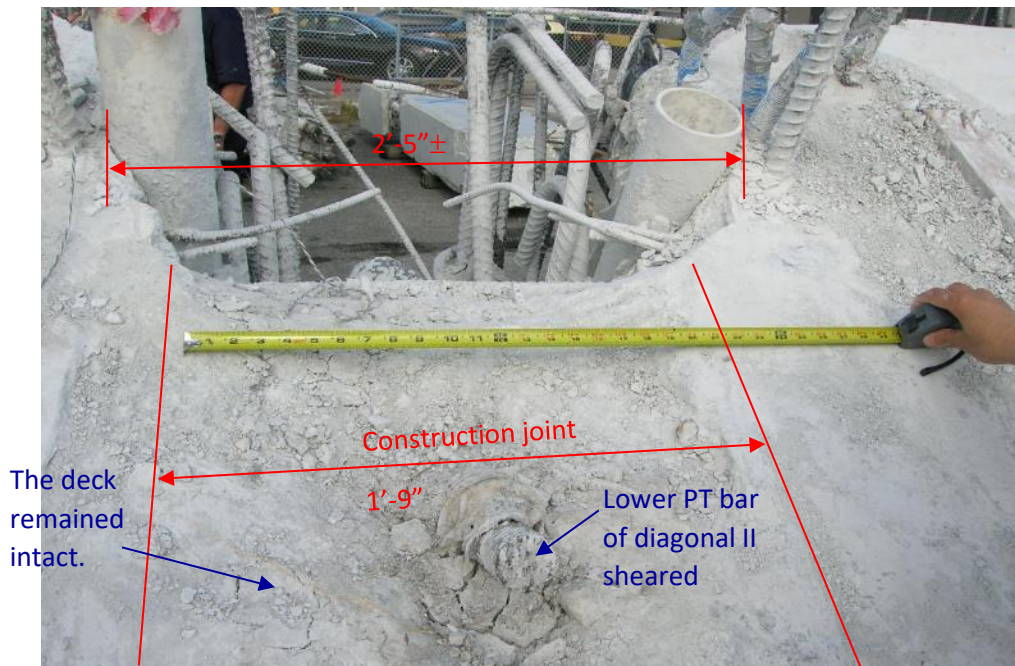

Figure 63 Blow-out hole in Diaphragm II at the time of the bridge collapse in the storage yard looking north from south, April 9, 2018, by OSHA



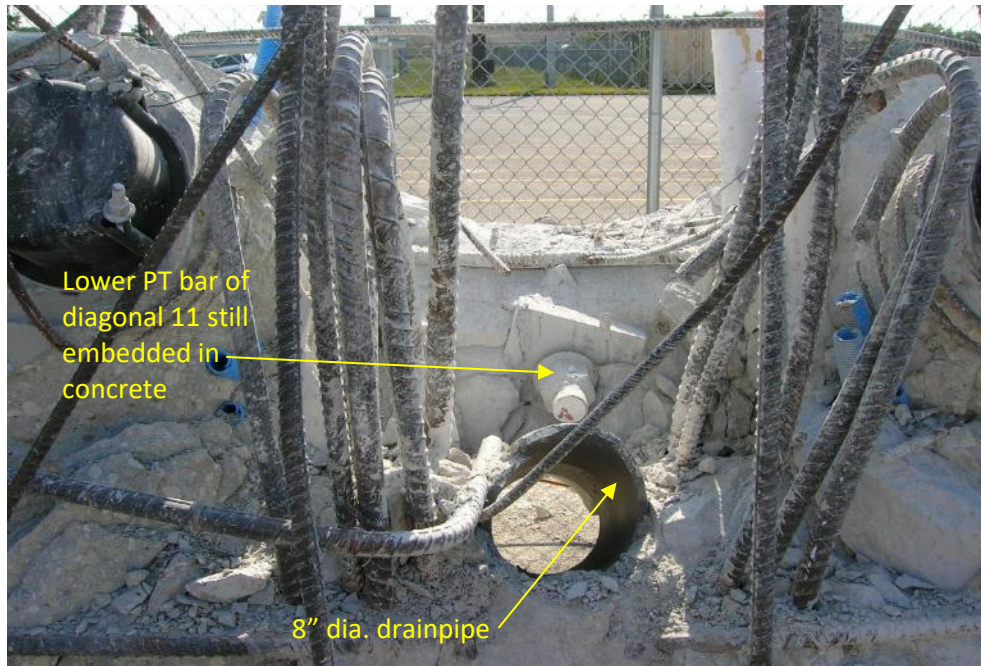

Figure 64 Punched hole in Diaphragm II at the time of the bridge collapse – from south looking towards north, April 9, 2018, by OSHA



Figure 65 Punched hole in Diaphragm II at the time of the bridge collapse – from south looking towards north, April 9, 2018, by OSHA



Figure 66 Punched hole in Diaphragm II at the time of the bridge collapse – from south looking towards north, April 9, 2018, by OSHA



Figure 67 Punched hole in Diaphragm II at the time of the bridge collapse – from south looking towards north, April 9, 2018, by OSHA



Figure 68 Punched hole in Diaphragm II at the time of the bridge collapse – from south looking towards north, April 9, 2018, by OSHA



Figure 69 Punched hole in Diaphragm II at the time of the bridge collapse – from south looking towards north, April 9, 2018, by OSHA



Figure 70 Punched hole in Diaphragm II at the time of the bridge collapse – from south looking towards north, April 9, 2018, by OSHA



Figure 71 Side view of the saved portion of the diaphragm II in storage yard, April 9, 2018, by OSHA



Figure 72 Aerial view of the collapsed bridge, March 15~18, 2018



Figure 73 South end of the bridge after collapse – looking west



Figure 74 South end of the bridge after collapse – looking east

The collapse crushed five motorists in their cars that were stopped at the traffic light at the time of the collapse, see Figure 75. As stated earlier, one VSL employee was fatally injured and another VSL employee was critically injured.



Figure 75 Vehicles crushed by falling bridge

## 8. Structural analysis:

Three-dimensional (3D) finite element models of the main span truss system of the bridge were created in STAAD.Pro, as shown in Figure 76. All concrete components, including the canopy, the vertical and diagonal truss members (members 1 to 12), the deck, and deck diaphragms I and II, were modeled using 3D plate elements. All the steel post-tensioning tendons were modeled using truss elements by sharing the nodes with the plate elements. Therefore, the post-tensioning tendons were coupled to the concrete structures.

The plate element in STAAD.Pro is a 3-noded (triangular) or a 4-noded (quadrilateral) element to which thickness was assigned as a property. The plate element had both attribute membrane (in-plane effect) and bending (out-of-plane effect). To check whether the plate element in STAAD.Pro was valid to model 3D frame systems, verification studies had been carried out before the main span truss system was modeled using the plate elements in STAAD.Pro. Structural models of the bridge main span are shown in Figure 76.

The truss element used to model the steel post-tensioning tendons is a uniaxial tension-compression element with three degrees of freedom at each node. No bending of the element is considered to represent the real condition in the structural members. The negative temperature difference was created in each single steel post-tensioning tendon to induce the post-tensioning force in the tendon. As stated earlier the post-tensioning tendons were coupled to the concrete structures by sharing the nodes. The numerical simulation of either a bonded (before grouting) or un-bonded post-tensioned member requires an un-bonded formulation to simulate the real bonding condition between the concrete and the steel post-tensioning tendons. Therefore, varied temperature drops were applied as inputs to different truss elements so the contraction forces in the steel post-tensioning tendons match the actual post-tensioning forces in the bridge. The magnitudes of the post-tensioning forces were adopted from the post-tensioning schedule prepared by FIGG Bridge Engineers, Inc. (FIGG).

Same material properties for the concrete and tendon steel as used by FIGG in the structural design were adopted and used in current analyses. To study the structural behavior of the main span truss system, as well as to determine the member forces in each truss member, only the

dead load of structural components and nonstructural attachment (DC), and the forces from post-tensioning (PS) were considered in linear static analyses. Four independent cases as listed below were studied:

- Case 1: No post-tensioning tendons in the main span truss system;
- Case 2: All post-tensioning tendons in the main span truss system, including in member No. 2 and 11;
- Case 3: Post-tensioning tendons in the main span truss system, except in member No. 2 and 11; and
- Case 4: Post-tensioning tendons in the main span truss system, except in member No. 2.

The outputs from the numerical simulations include member end forces and moments from all truss members from the loads applied to the structure and shear and normal forces at the construction joints at the intersections of the deck and Members 1 and 2 and Members 11 and 12.



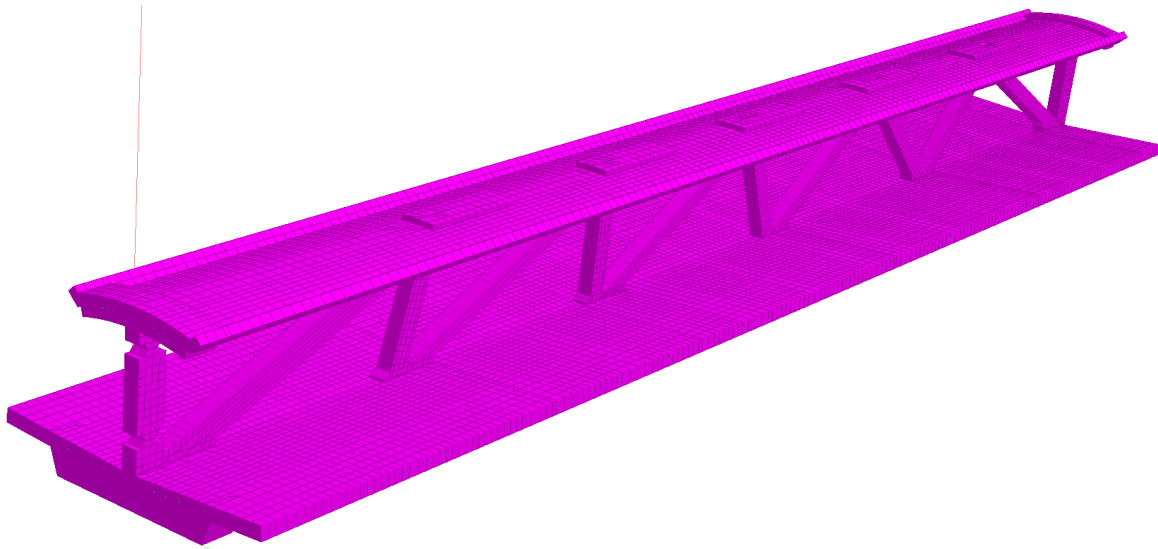

Concrete

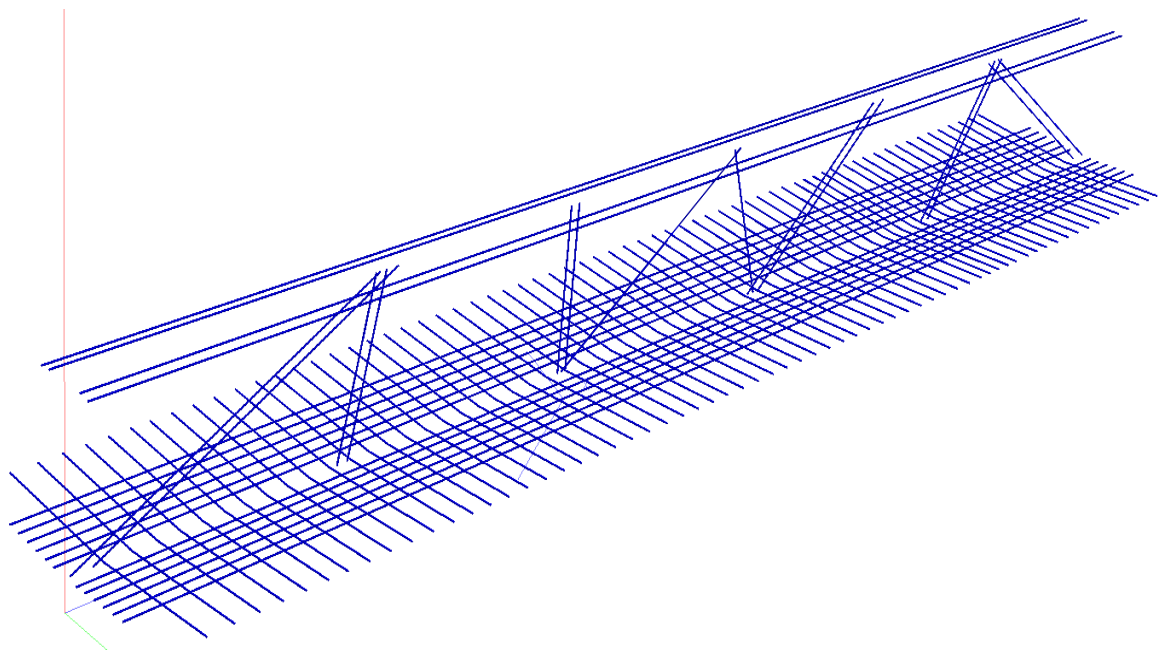

Tendons

Figure 76 Overview of the main span truss system model

## 9. Structural design deficiencies:

### Construction joint and inadequate shear transfer:

Construction joints (CJ) are unavoidable in such large structures but should be addressed by the design engineer in an acceptable manner in accord with industry standards. Of significance to this investigation was the construction joint between diagonal 11 and the bridge deck.

Reproduced below in Figure 77 is the detail entitled “Truss members 11 & 12 connection detail” from drawing B-61 with construction joint identified. Industry standard is to “consider shear transfer across a given plane, such as an existing or potential crack, an interface between dissimilar materials or an interface between two concrete cast at different times.” The construction joint at the bottom of the diagonal 11, therefore, qualifies for evaluation of the shear friction. This bridge is a concrete truss bridge weighing approximately 1,900 kips. Therefore the forces in the truss members are high. We will analyze the construction joint for shear friction by LRFD Bridge Design Specifications by AASHTO, seventh edition.

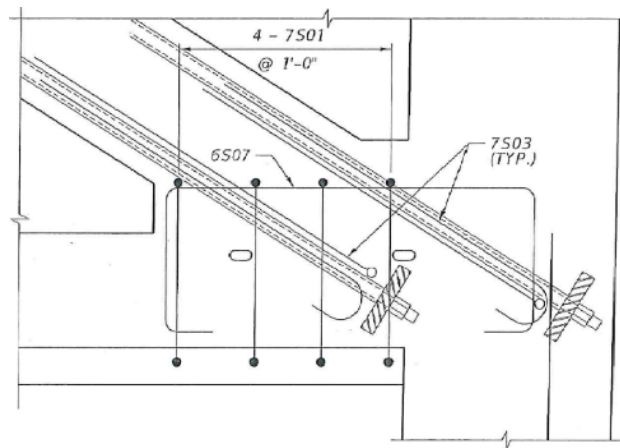

Figure 77 Construction joint detail at diagonal 11 and deck.

The axial force in the diagonal 11 of the main span after the PT bars were de-stressed was computed to be approximately 1,312 kips without considering any load factors. The shear friction is resisted by the tension in the rebar crossing the plane of the construction joint. If there is a vertical compressive force clamping the construction joint, then the compressive force is also employed to aid in the resistance of the shear friction. Industry standard also requires that “Permanent net compression across shear plane shall be permitted to be taken as additive to  $A_v f_y$ ,

the force in the shear friction reinforcement, when calculating required  $A_v f_y$ ". In this case, 705 kips is estimated to be the compressive force at the joint. There were a number of rebar crossing the construction joint, but not all bars could be considered for shear transfer because of lack of development length. Industry standard requires that "shear friction reinforcement shall be appropriately placed along the shear plane and shall be anchored to develop  $f_y$  on both sides by embedment, hooks or welding to special devices." This criteria excluded some of the rebar crossing the construction joint.

The next question was whether the interface between the two pours was smooth or "intentionally roughened" to a full amplitude of  $\frac{1}{4}$ ". The construction documents prepared by FIGG did not specify that the construction joints be "intentionally roughened" with an amplitude of  $\frac{1}{4}$ " to provide higher value of shear friction at the junction of the diagonals and the deck, as required by AASHTO. During interview with OSHA, FIGG presented the argument that the standard FDOT specification already covered this requirement, and therefore it was not indicated on the construction plans. FIGG referred to FDOT specification 400.9.3 entitled "Preparation of Surfaces" that states that *before depositing new concrete on or against concrete that has been hardened, re-tighten the forms. Roughen the surface of the hardened concrete in a manner that will not leave loosened particles, aggregate, or damaged concrete at the surface. Thoroughly clean the surface of foreign matter and laitance, and saturate it with water.*" The above requirement does not cover intentionally roughened with an amplitude of  $\frac{1}{4}$ " to obtain higher shear friction values. It is interesting to note that FIGG, on sheet B-24B and B-25, for a different location of the project required that the surface of the intermediate pylon be roughened to an amplitude of  $\frac{1}{4}$ " before casting back span, and did not rely on FDOT specification cited above. If the structural engineer relies on higher friction value, then the engineer must specify it on the contract plans, as was done in the case of the pylon and the back truss, and not rely on FDOT. Field observation indicated that the construction joints were not intentionally roughened with an amplitude of  $\frac{1}{4}$ ".

For this analysis, a non-roughened surface was considered. The diagonal axial force in 11 could be resolved into a horizontal force of approximately 1,106 kips without any load factor, and a perpendicular to the shear plane force of 705 kips. The capacity of the joint to resist shear

friction was estimated to be 906 kips without any phi factor. The demand is 22% above the available strength. The above condition existed on Saturday, March 10, 2018, until noon of Thursday, March 15, 2018.

On March 13, 2018, and on March 15, 2018, FIGG instructed the contractor to re-tension the two PT bars in diagonal 11 to a force of 280 kips each incrementally with approximately 50 kips re-tension at a time alternating between the upper and lower PT bars. It is understood from Structural Technologies employees that at the time of the collapse, both PT bars were re-tensioned to the desired force of 280 kips each. The re-tension of March 15, 2018, worsened the situation at the shear plane. On the one hand, it increased the clamping force to 1,006 kips from 705 kips, but on the other hand, the shear friction force was also increased to 1,579 kips from 1,106 kips. The capacity to resist shear friction increased to 1,086 kips. The demand was 45% higher than the available strength without considering any load factors or phi factors. But this capacity did not consider that even prior to re-tensioning, the construction joint was already slipping and failing as shown in a number of figures in the previous sections. The actual capacity would be significantly lower. The failure occurred when the re-tensioning was completed at the lower bars in diagonal 11.

Therefore, adequate shear transfer was not provided at the construction joint which would prevent a slip across the joint. Reinforcements crossing the construction joint were inadequate to provide shear transfer. In addition, other than the rebar in column 12, rebar crossing the CJ did not have adequate embedment on the diagonal side of the CJ.

We also examined the similar situation at the junction of diagonal 2 and the deck where re-tensioning of the PT bars in diagonal 2 did not occur. The two PT bars in diagonal 2 were de-stressed on Saturday, March 10, 2018, and remained so until the collapse. The node at the bottom of diagonal 2 did not fail. It must be noted here that there are significant differences between the shear plane at diagonal 11 and diagonal 2. Diagonal 2 is 3 ft. deep compared to diagonal 11 being 2 ft. There were 14 #11 rebar crossing the shear plane at column 1 compared to three #11 and nine #7 at column 12. The contact area of the shear friction at diagonal 2 was  $21 \times 112 = 2,349$  sq.in compared to  $21 \times 76 = 1,596$  sq.in for diagonal 11. In diaphragm II, there were two 4" ID plastic pipes on each side of the column 12 creating weak points where cracks

could initiate and propagate. The center line of the pipes were 2" and 2½" away from the face of column 12 right against the face of the column 12. There were no such pipes embedded in diaphragm I on either side of column 1. The axial force in diagonal 2 was computed to be approximately 1,764 kips with a shear friction force of 1,613 kips without considering load factors. The available capacity was computed to be 1,391 kips without considering phi factor. The demand was 16% higher than the available strength. The reason why the failure did not occur at that location could be attributed to factors like the actual shear friction resistance is higher than the values permissible by AASHTO or participation of additional rebar not considered in accordance with AASHTO.

#### Redundancy:

Industry considers redundancy a critical factor in structural design. The structure of the main span was determinate, and was non-redundant. The forces in the members of the main span truss could be determined by equations of statics and equilibrium by making discreet and judicious assumptions, and therefore is a non-redundant structure. There was a single line of truss at the center, and if one diagonal failed, the entire bridge would collapse. Multiple load paths were not provided to distribute loads of a diagonal, in the event it failed, to other structural members which would have been possible in a redundant structure. The main span of the bridge was cast in concrete and was supported on a pier and pylon during stage 3. The single truss was 18' tall to support the 31' wide concrete deck and 16' wide concrete canopy. The configuration of the truss was ordinary except that the diagonal truss members were not symmetrical to the center line, and were inclined in a manner that they coincided with the axes of the pipe members framing into the truss and the future 109' tall pylon. Configuration described herein did not contribute to the collapse. Concrete trusses are rare but they do exist. Steel trusses are preferred because steel is ductile and could cope better with incidental flexural forces, particularly when the bridge is being assembled in an off-site location and then relocated to its final location, and constructed in stages.

The design criteria prepared by TY Lin for FIU recommended avoiding non-redundant structures and encouraged a steel superstructure. The design criteria stated that "*The bridge superstructure should be primarily structural steel with concrete walking surface. The design should avoid*

*use of **non-redundant, fracture critical members.***” (Emphasis ours.) The selection committee was swayed by the graphics and rendering of the bridge and did not consider the non-redundancy of the structure. During interviews with OSHA following the incident, FIGG engineers stated that because there were multiple PT bars and tendons in the structure, it could be classified as a redundant structure. This statement does not lend itself to the non-redundancy of the structure.

Transfer of tensile forces to the deck:

Also refer to Chapter 6.0 “The Cracks”. There is no viable mechanism to capture the horizontal tensile forces from the diagonal 11 to the deck. During stage 3, diagonals 2 and 11 were the primary load path to carry the majority of the dead load of the main span truss to the south pier and north pylon respectively. Diagonal 11 had an approximate axial compressive force of 1,312 kips after de-stressing the PT bars in diagonal 11. This axial diagonal force created a horizontal tension of 1,107 kips which needed to be transferred to the deck. If the PT bars in diagonal 11 are re-tensioned, as was the case on March 15, 2018, an additional axial force of 580 kips is introduced in diagonal 11. The horizontal tension would then increase to 1,595 kips, as it happened immediately before the collapse. A review of the details of the diagonal 11 and the deck indicates that there is no mechanism to transfer the tensile force from the diagonal to the deck. The center truss is rigid compared to the deck, and most of the forces will tend to remain in the truss members rather than distribute in the 31’-8” wide deck with 9½” as the minimum thickness. This also created shear lag in the deck. The PT tendons D1 thru D6 are placed away from the junction of the diagonal and the deck, and there are no PT tendons at the center of the deck due to the location of a drain pipe, although the drain pipe could have been located elsewhere. Therefore, the compressive force imposed by the tendons, D1 thru D6 in the deck are not effective in resisting the tensile forces in the immediate vicinity of the north end. There are nominal bundles of #4 rebar which are not capable of resisting such a large force. D1 is the nearest tendon to the center of the deck. If an effective zone is created at D1 on both sides of the column 12 at an angle of 45 degrees towards the south, it misses the junction of the centerline of diagonal 11 with the top of the deck rendering it unable to resist any portion of the tensile forces, see Figure 79. At the 45 degrees line where the compression and tension areas meet, potential cracks would appear. D2 thru D6 are much farther away to capture the tensile load in an effective way at the north end. This was an inherent weakness in the design during the stage 3.

This weakness would not exist after the intermediate pylon and back span were completed in the future. A review of the pictures of the cracks reported to FIGG by MCM on March 12, 2018 and March 13, 2018 indicate that such cracks, in fact, occurred along that line on both sides of column 12. These cracks were occurring at a horizontal tensile force of 1,107 kips. When the force was increased to 1,595 kips due to re-tensioning of the PT bars in diagonal 11, the collapse occurred.

#### Location of the drain pipe and the embedded pipes in diaphragm II

A 12" dia. semicircular cut was made in the center of the deck to accommodate an 8" round drain pipe. This not only reduced the cross sectional area of the deck at the key location but prevented the placement of any PT tendons or heavy mild reinforcement to capture the horizontal force from the deck. There was a 4" and 4½" diameter plastic pipe placed right against the columns in diaphragm II. Such locations often act as a crack initiator.

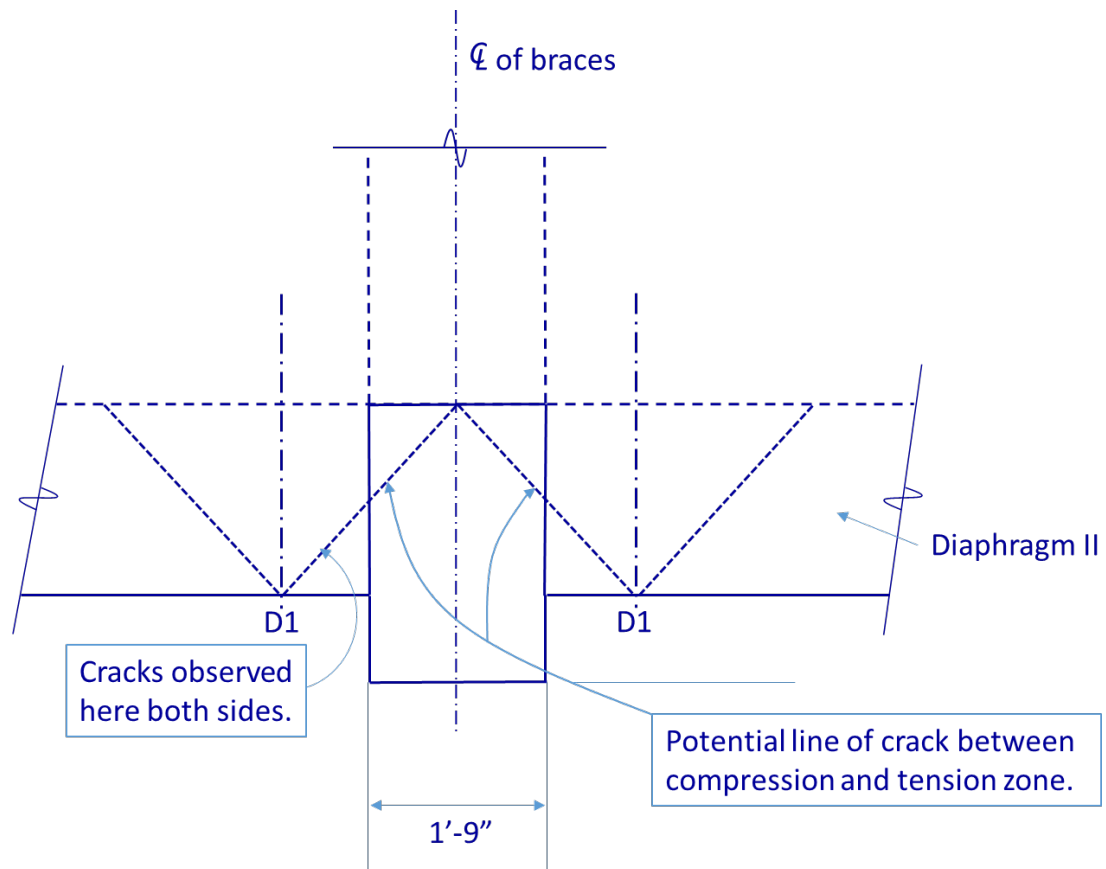

Figure 78 Potential line of crack – plan view

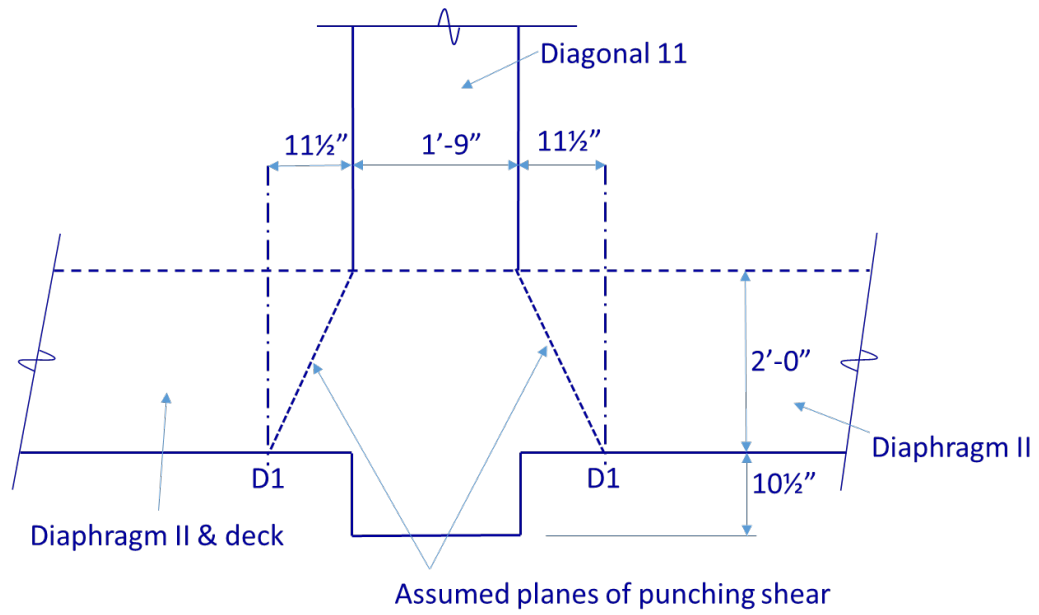

Figure 79 Potential Punching shear failure at north end – plan view



## 10. Conclusions

As a result of the investigation, OES concludes that:

1. FIGG Bridge Engineers (FIGG) ,the Engineer of Record (EOR) failed to recognize that the bridge was in danger of collapsing when he inspected it hours before the collapse. The concrete truss had developed numerous wide and deep structural cracks jeopardizing the integrity of the bridge. The EOR should have immediately instructed that the bridge be shored at appropriate locations and SW 8<sup>th</sup> Street be closed. At the time of collapse, the post-tensioning bars were being re-tensioned at the specific instructions of the EOR.
2. The bridge had structural design deficiencies that contributed to the collapse during construction stage III. The cracks on the bridge occurred due to deficient structural design.
3. The morning of the incident, EOR held a meeting with project participants after evaluating the cracks over the course of the previous two days. At that meeting, the EOR acknowledged that his computations could not replicate the cracks and therefore, he did not know why the cracks were occurring. The Construction Engineer and Inspector (CEI) of the project advised the EOR at this meeting that the cracks were lengthening daily. Despite these admissions and the knowledge that the cracks were growing in size, EOR stated more than once that the cracks did not present any safety concerns.
4. The magnitude of the cracks warranted that SW 8th Street be immediately closed, and the concrete truss be shored and supported at multiple intermediate locations to reduce the loads in the north diagonal and the node until final evaluations were done and remedial measures implemented.
5. Networking Engineering Services, Inc. dba Bolton Perez and Associates, Inc. (BPA) was retained by FIU to be the Construction Engineer and Inspector (CEI) of the project. BPA failed to classify the cracks, which were structural in nature, in accordance with the FDOT requirements. BPA, as a CEI, was expected to exercise its own independent professional judgement in accordance with their contract with FIU and Florida Department of Transportation (FDOT) requirements. With intimate knowledge of extensive cracking on the bridge, BPA failed to recognize that the bridge was in danger

of collapsing, and did not recommend to FIU, MCM or others to close the street and shore the bridge, regardless of the opinion held by the EOR.

6. Munilla Construction Management, Inc. (MCM), the design-build contractor, was aware that the cracks were “getting larger” as reported by MCM superintendent and quality control personnel on March 12 and 14, 2018. On March 13, 2018, EOR stated in an email to MCM, among the list of facts, that “since Saturday (March 10, 2018), MCM has been monitoring the cracks and they have not grown in size.” MCM should have immediately informed EOR on March 14, 2018 that this assumption was not valid. Despite this oversight on the part of MCM, the EOR was provided with photographs and measurements of the cracks in the days leading up to the collapse and was specifically informed by BPA during the morning meeting on March 15, 2018 that the cracks were lengthening.
7. MCM, the design-build contractor, deferred to the decision of EOR and failed to exercise its own independent professional judgement, as a constructor of the bridge, to close the traffic on SW 8th Street until the cause of the cracks were conclusively determined by EOR and peer reviewed. MCM had extensive construction experience in concrete structures and had intimate knowledge of the magnitude of cracks which were growing in size daily. MCM’s deference to EOR in light of the conclusion No. 6 above, and failure to exercise their own independent judgment with regard to implementing necessary safety measures were unreasonable.
8. The evaluations of the cracks by the EOR, and his recommendation to re-tension the post-tensioning bars of diagonal 11, were not included in the original design and therefore should have been subject to peer review.
9. The consultant retained by EOR to conduct independent peer review of the EOR’s design, as per FDOT requirements, did not check the structural integrity of the bridge under different construction stages, a violation of the FDOT requirements. The independent check was performed only under the final design stage when all segments of the bridge were constructed and completed.
10. EOR failed to provide construction documents to Louis Berger at 30%, 60% and 90% of completion of construction documents, in accordance with the FDOT requirements.

11. The EOR should have known that the consultant who conducted the peer review did not check the structural design of the truss design at stage III, as required by FDOT, meriting extra safety precautions by EOR.
12. EOR should have known that the truss was a non-redundant structure and if one diagonal member failed, the entire bridge could collapse. Given the nature and extent of the cracking and the non-redundancy of the bridge design, necessary safety precautions should have included closing the roadway below the bridge and immediately providing shoring to the bridge at suitable locations until a complete evaluation was done.